

CONCLUSIONES

- El Sistema de Supervisión y Control de la Planta de Tratamiento de Efluentes de Pequiven, instalado actualmente, está colapsado, debido al crecimiento en volumen del proceso, ya que no existe posibilidad de anexas nuevas señales, diagramas del proceso y aplicaciones de control. Aunado a esto el controlador UDC-9000, fue declarado obsoleto, por el fabricante, por lo que no se consigue repuestos para este sistema en el mercado nacional e internacional; lo que puede provocar la salida de servicio de todo el sistema de control.
- Los sistemas RsLogix y ControlLogix, por sus características, conforman un sistema Supervisorio de Control, adecuado a las exigencias del proceso de la Planta de Tratamiento de Efluentes de Pequiven, ya que permite además de realizar las operaciones, la elaboración de aplicaciones y diagramas de control y la incorporación de todas las señales actuales y futuras del proceso. Es una tecnología nueva, en cuanto a que se pueden realizar acciones de control a través del PLC ControlLogix, capaz de sustituir el sistema de control actual.
- El Hardware y equipamiento necesario para la implantación del Sistema Supervisorio de Control, utilizando RsLogix y ControlLogix, es tecnología nueva de la empresa Allen Bradley y que garantiza el suministro de partes y repuestos hasta por quince años y que además se caracteriza por desarrollar nuevas tecnologías sin que se pierda las plataformas actuales, lo que en un

futuro permitiría la migración a un sistema nuevo a bajos costos.

- La Arquitectura del sistema Supervisorio de Control RsLogix y ControlLogix que se propone, se adecua a las exigencias tecnológicas, económicas y de seguridad de la empresa Pequiven, ya que le permitirá un control adecuado de las operaciones de la Planta de Tratamiento de Efluentes.

RECOMENDACIONES

Dentro de las recomendaciones presentadas a la Empresa Pequiven, para la implementación de la propuesta del Sistema Supervisorio y Control de la Planta de Tratamiento de Efluentes se encuentran las siguientes:

Formular en el Presupuesto de Inversiones y Proyectos Operacionales para el año 2006, los gastos asociados a la propuesta del Sistema de supervisión de Control, adicionalmente a los gastos previsto por concepto de mantenimiento preventivo y correctivo de los mismos, para lo cual se presentó el informe respectivo, donde se incluyen los costos por materiales, equipos, software y hardware mas los gastos por servicio técnico, para la instalación, pruebas y puesta en marcha del sistema. Ver Anexo B.

BIBLIOGRAFIA

- Allen Bradley: Industrial control of all types. www.ab.com.
- Bavaresco, Aura., (1979). Las Técnicas de la investigación. México; Grupo Editorial Iberoamericana, 4ta. Edición.
- Chávez, N. (1984). Introducción a la investigación educativa. (1ra. Edición). Maracaibo: ARS Grafica.
- Creus S., Antonio. (1978) Instrumentación Industrial (6ta. Edición). Barcelona, España: Alfaomega.
- Fuenmayor, H. (2001) Tesis: "Implantación de un sistema Supervisorio y Control para el Complejo de Compresión de Gas LAMARGAS, ubicado en el Lago de Maracaibo", Universidad del Zulia.
- Hernández S., R.; Fernández C., C. y Baptista L., P. (1998). Metodología de la investigación. (2da. Edición). México, D.F.: McGraw Hill.
- Martínez M., Miguel A. (2004) Tesis: "Sistema de Control Supervisorio generalizado Convencional e Inteligente para Centrales de Generación de Ciclo Combinado". México. Diciembre.
- Ogata, Katsuhiko. (1970) Ingeniería de Control Moderna. México: Prentice Hall.
- Prato, C. (1997) Tesis: "Implantar un Sistema de Control y Adquisición de Datos Scada en los pozos petrolíferos pertenecientes a la empresa Chevron ubicada en Campo Boscan", Universidad del Zulia.
- Rodríguez, P. (1994) Tesis: "Automatización de Operaciones en la Refinería el Palito, de Corpoven, S.A." Universidad del Zulia.
- Smith C.A., Corripio A.B. (1991) Control Automático de Procesos. Teoría y Práctica, México: Limusa.
- Torres, Y. (1001) Tesis: "Sistemas de Supervisión y Control para la automatización del Sistema de Tratamiento de Agua en una Planta Generadora de Vapor", Universidad Dr. Rafael Beloso Chacín.
- http://literature.rockwellautomation.com/idc/groups/literature/documents/pp/9324-pp01_-en-p.pdf.

http://literature.rockwellautomation.com/idc/groups/literature/documents/in/1756-in101_-en-p.pdf.

http://literature.rockwellautomation.com/idc/groups/literature/documents/sg/1756-sg001_-en-p.pdf.

http://literature.rockwellautomation.com/idc/groups/literature/documents/um/1756-um523_-en-p.pdf.

http://www.honeywell.es/hw_products_servicios/hw_sensores/Hw_MC/Hw_Soluciones_integradas.htm#Controlador%20S9000.

www.honeywell.com.

http://content.honetwell.com/ipc/faq/pdf/S9000_documentation.pdf.

ANEXOS

ANEXO B
EVALUACIÓN DEL SISTEMA DE SUPERVISION Y CONTROL

DE LA PLANTA DE TRATAMIENTO DE EFLUENTES

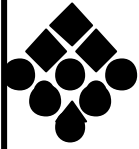

PEQUIVEN

**PETROQUIMICA DE VENEZUELA, S.A.
GERENCIA DE MANTENIMIENTO
COMPELJO ZULIA**

**EVALUACIÓN DEL SISTEMA DE SUPERVISIÓN Y CONTROL DE LA
PLANTA DE TRATAMIENTO DE EFLUENTES**

ENERO 2005

SISTEMA DE CONTROL DISTRIBUIDO

PLANTA: EFLUENTES PRINCIPAL

INTRODUCCIÓN

En la actualidad, la operación de la Planta de Tratamiento de Efluentes posee el sistema de control UDC-9000, el cual realiza el monitoreo y control de las operaciones de la planta. Este sistema no es lo suficientemente confiable para el tratamiento de los efluentes, ya que no cuenta con un sistema supervisorio que interactúe con el personal que opera y mantiene la planta, lo que no permite visualizar y operar los equipos del proceso, en tiempo real y transparente, utilizando despliegues gráficos de operación desde una estación o terminal de Interface del usuario con el UDC-9000.

La falta de un sistema supervisorio para el sistema de control de la Planta de tratamiento de Efluentes, provocan fallas en el control de los efluentes tales como: derrames en las fosas de tratamiento; arranque o paro de equipos mezcladores y bombas fuera de tiempo; cierre o apertura de válvulas; la no visualización de un historial o tendencia de las variables controladas, lo que se traduce en daños ambientales.

El Sistema de Control Distribuido instalados en la Planta de Tratamiento de Efluentes del Complejo Zulia, se encuentra totalmente inoperativo, no existen estaciones de trabajo y el Panel View, esta dañado. Todo el Sistema de Supervisión y Control es Obsoleto, declarado por el Fabricante Honeywell.

La justificación de sustitución del Sistema actual se basa en:

Económico

Toda planta industrial tiene como meta la continuidad de sus procesos para maximizar su producción e incrementar sus ingresos, como es el caso de la planta de Tratamiento de Efluentes que opera las 24 horas del día. La actualización del sistema permitirá un proceso estable con lo cual disminuirán las fallas de la planta y emanaciones innecesarias al ambiente, y en consecuencia un incremento de los beneficios económicos de la empresa.

Seguridad

Garantizar la seguridad de las personas que trabajan en el Complejo, del medio ambiente, y las instalaciones, de allí parte que la actualización se desarrolle en beneficio de mantener las metas de la empresa, y en este caso particular, dado que el sistema de control UDC-9000, ha presentado fallas no convenientes por las condiciones operacionales que exige el proceso, lo cual induce en inseguridad y contaminación ambiental, que deben corregirse.

Tecnológico

La actualización nos da la posibilidad de lograr un crecimiento de los procesos vinculados a la actividad de la empresa, de tal manera que incorpora un sistema de trabajo adecuado a sus exigencias, resguardando los intereses de la institución y aportando un mecanismo aplicable al mejoramiento de su gestión operativa reflejándose en los niveles de seguridad, productividad, rendimiento y beneficios.

CONDICION DEL SISTEMA

Sistema Supervisorio

- **Conformado por dos PC y un Panel View:** Las PC's no se encuentran en sitio, su configuración eran Pentium I, no acorde a las Tecnologías Actuales, no permitirían la carga de los Software, que se fabrican para ejecutar Supervisión y Control de Procesos. El Panel View, esta obsoleto, adicionalmente se daño por problemas eléctricos.

Sistema Control UDC-9000

- **Conformado por un PLC Honeywell con controlador de la serie S9000 y tarjetas I/O de la serie 620:** Estos equipos fueron declarados obsoleto por el fabricante Honeywell, lo que no garantiza la ubicación de repuestos en el mercado, ya que no se elaboran en la actualidad.

- **Sistema Operativo**

R534

- **Equipos en vía de obsolescencia:**

- Model 9000e Controller.
- Control Logic Processor Model 9000.
- Ethernet Loop Processor Module (ELPM/LPM).
- Power Supply (8/15 Amp).

- Isolated Analog Input Module.
 - Analog Output Module.
 - Pulse Input Module.
 - 115 Vac Digital Input Module.
 - 24 Vdc Digital Input Module.
 - 115 Vac Digital Output Module.
 - 24 Vdc Digital Output Module.
 - 115 Vac Isolated Digital Output Module.
 - 115 Vac Isolated Digital Output Module.
 - Asynchronous Port Minicop Module.
 - Enhanced Diagnostics Module.
 - Reed Relay Module.
 - Serial Link Module.
 - Resistance temperature Detector Module.
- **Equipos y periféricos para ser reemplazados por daños y desperfectos:**
 - 1 Panel View

PROPUESTA DE ACTUALIZACION

Esta actualización contempla:

- **Reemplazo del Sistema Supervisorio por el Sistema RsLogix de Allan Bradley , el cual permite:**
 - Despliegues de Menú de navegación.

- Despliegues de Resumen de Alarmas.
- Despliegues de Resumen de Eventos.
- Despliegues de Grupos de Operación.
- Despliegues de Tendencias.
- Despliegues de Sintonización de Lazos.
- Despliegues de Diagnósticos.
- Resumen de Despliegues.
- Reportes Estándar.
- Despliegues de Mantenimiento.

- **Reemplazo del Controlador UDC-9000 y tarjetas I/O por el Sistema ControlLogix de Allan Bradley, lo que nos ofrece:**
 - Ejecución de Lógicas en diagrama escalera
 - Control del Proceso
 - Reemplazo de componentes en caliente

Beneficios:

- Revalorización y repotenciación de los DCS del Complejo
- Mejoras en la capacidad de procesamiento, respuesta y desempeño de los sistemas de control
- Estandarización de las plataformas en hardware y software a tecnología actual y de vanguardia
- Disponibilidad y posibilidad de implantar y/o integrar la base de datos a

sistemas estadísticos o sistemas de información operacional y gerencial a nivel del Complejo (filosofía de sistemas abiertos)

- Actualización a Tecnologías nuevas con disposición de herramientas utilitarias, diagnósticos y configuración y además posibilidad de implantar nueva tecnología fieldbus
- Repuestos y soporte técnico garantizado por un período mínimo de 15 años

Equipamiento requerido para ejecutar la Actualización:

Para el Sistema RsLogix:

Descripción	Valor
Computador Personal (02 Servidor / 02 Estaciones de Trabajo)	Pentium IV, o Pentium III 733 MHz
Requerimientos de Software	Sistemas operativos con soporte: Microsoft® Windows XP (Professional version 2002 o XP Home version)
Memoria RAM	128 Mbytes de RAM mínima 256 Mbytes de RAM recomendada
Espacio en Disco Duro	100 Mbytes de espacio libre en disco duro (o mayor basado en los requerimientos de las Aplicaciones)
Requerimientos de Video	256-color VGA adaptador grafico 800 x 600 resolucion mínima (Color 1024 x 768 recomendado)

Para el Sistema ControlLogix:

Renglón	Descripción	Cantidad	Unidad
01	Rack de 17 Ranuras, para ControlLogix 1756-A17K	01	Pza.
02	Rack de 10 Ranuras, para ControlLogix 1756-A10K	01	Pza.
03	Rack de 7 Ranuras, para ControlLogix 1756-A7K	02	Pza.
04	Modulo 1756-CNBK para la conexión entre sala de Control y el PLC ControlLogix	02	Pza.
05	Modulo para adaptación de fuente redundante 1756-PSCA2	02	Pza.
06	Modulo 1756-CNBR para comunicación DeviceNet, con chasis remoto	04	Pza.
07	Módulos Fuente de Poder Redundante 1756-PA75R para Rack ControlLogix	02	Pza.
08	Módulos Fuente de Poder Redundante 1756-PA75R, para Rack remoto.	02	Pza.
09	Procesador Logix5561 1756-L61K	02	Pza.
10	Módulos 1756-IB16 (80 señales discretas de entrada).	05	Pza.
11	Módulos 1756-OB16I (32 señales discretas de salida).	02	Pza.
12	Módulos 1756-IF6CIS (80 señales analógicas de entrada).	13	Pza.
13	Modulo 1756-IF8K (24 señales analógicas salida de 4-20mA).	03	Pza.
14	Cables para conectar Fuentes de poder redundantes (1756-CPR2)	02	Juego (par)
15	Modulo de Redundancia del Sistema 1757-SRM	02	Pza.
16	Modulo de Fuente para Chasis del Procesador 1756-PA75	02	Pza.
17	Panel View Plus 1500 ControlNet & Standard Comm 2711P-K15C15B2	01	Pza.
18	Impresora	01	Pza.
19	Sistema RsLogix 5000 Pro edition, English 9324-RLD700NXENE (incluye el software RsView)	01	Pza.

Estimado de costos clase II: 195, oo MMBs.

El Servicio requerido para ejecutar la Actualización, contempla todos los trabajos asociados a las siguientes actividades:

- Suministro del Hardware y Software para el Sistema de Control.

- Desmontaje de equipos e Instalación y cableado de nuevos equipos en gabinetes existentes.
- Programación, Carga y Pruebas de Lógica de Control del PLC.
- Elaboración de Pantallas (Esquemáticos o Despliegues)
- Asistencia Técnica durante el Arranque y Puesta en Servicio del Sistema.
- Documentación de los Sistemas.
- Adiestramiento.

Estimado de costos clase II: 165, 00 MMBs.

PRESUPUESTO REQUERIDO PARA EL SISTEMA DE SUPERVISION Y CONTROL SERIE LOGIX DE ALLAN BRADLEY

▪ **Plan de Actualización (ver nota) 360, 00 MMBs.**

Total: 360, 00 MMBs.

Nota: Sujeto a disminución en cuanto a la viabilidad de continuidad operacional de la planta Efluentes

RECOMENDACIÓN

Formular en el Presupuesto Operacional para el año 2006 los gastos asociados a la Actualización de los Sistemas en adición a los gastos previstos por concepto de mantenimiento preventivo y/o correctivo de los mismos.

**Atentamente,
Rafael Dávila**

Sup. Electrónica



ControlLogix Selection Guide

**1756-L55, 1756-L61, 1756-L62,
1756-L63, 1756-L60M03SE**

**Rockwell
Automation**

Logix Controllers Comparison

Common Characteristics	1756 ControlLogix™	1769 CompactLogix™	1789 SoftLogix5800™	1794 FlexLogix™	PowerFlex 700S® with DriveLogix
controller tasks: <ul style="list-style-type: none"> continuous periodic event 	<ul style="list-style-type: none"> 32 tasks (only 1 continuous) event tasks: supports all event triggers 	<ul style="list-style-type: none"> 1769-L35E: 8 tasks 1769-L32E: 6 tasks 1769-L31: 4 tasks 1769-L20, -L30: 4 tasks only 1 task can be continuous event tasks: supports consumed tag trigger and EVENT instruction 	<ul style="list-style-type: none"> 32 tasks (only 1 continuous) event tasks: supports all event triggers, plus outbound and Windows events 	<ul style="list-style-type: none"> 8 tasks (only 1 continuous) event tasks: supports consumed tag trigger and EVENT instruction 	<ul style="list-style-type: none"> 8 tasks (only 1 continuous) event tasks: supports axis and motion event triggers
user memory	1756-L55M12: 750 Kbytes 1756-L55M13: 1.5 Mbytes 1756-L55M14: 3.5 Mbytes 1756-L55M16: 7.5 Mbytes 1756-L55M22: 750 Kbytes 1756-L55M23: 1.5 Mbytes 1756-L55M24: 3.5 Mbytes 1756-L61: 2 Mbytes 1756-L62: 4 Mbytes 1756-L63: 8 Mbytes	1769-L20: 64 Kbytes 1769-L30: 256 Kbytes 1769-L31: 512 Kbytes 1769-L32E: 750 Kbytes 1769-L35E: 1.5 Mbytes	1789-L10: 2 Mbytes 3 slots no motion 1789-L30: 64 Mbytes 5 slots 1789-L60: 64 Mbytes 16 slots	1794-L33: 64 Kbytes 1794-L34: 512 Kbytes	256 Kbytes 768 Kbytes with memory expansion
nonvolatile user memory	1756-L55M12: none 1756-L55M13: none 1756-L55M14: none 1756-L55M16: none 1756-L55M22: yes 1756-L55M23: yes 1756-L55M24: yes 1756-L61: CompactFlash 1756-L62: CompactFlash 1756-L63: CompactFlash	1769-L20: yes 1769-L30: yes 1769-L31: CompactFlash 1769-L32E: CompactFlash 1769-L35E: CompactFlash	none	1794-L33: yes 1794-L34: yes	yes (expansion memory)
built-in communication ports	1 port RS-232 serial (DF1 or ASCII)	<ul style="list-style-type: none"> 1769-L20 has 1 RS-232 serial port (DF1 or ASCII) 1769-L30, -L31 has 2 RS-232 ports (one DF1 only, other DF1 or ASCII) 1769-L32E, -L35E has 1 EtherNet/IP port and 1 RS-232 serial port (DF1 or ASCII) 	depends on personal computer	<ul style="list-style-type: none"> 1 port RS-232 serial (DF1 or ASCII) 2 slots for 1788 communication cards 	<ul style="list-style-type: none"> 1 port RS-232 serial (DF1 or ASCII) 1 slot for 1788 communication cards
communication options (these options have specific products and profiles for their platform - other options are available via 3rd party products and generic profiles)	EtherNet/IP ControlNet DeviceNet Data Highway Plus Universal Remote I/O serial Modbus via ladder routine DH-485 SynchLink	EtherNet/IP DeviceNet serial Modbus via ladder routine DH-485	EtherNet/IP ControlNet DeviceNet serial	EtherNet/IP ControlNet DeviceNet serial Modbus via ladder routine DH-485	EtherNet/IP ControlNet DeviceNet serial Modbus via ladder routine DH-485
controller redundancy	full redundancy support	not applicable	not applicable	controller hot backup via DeviceNet	not applicable
native I/O	1756 ControlLogix I/O	1769 Compact I/O	none	1794 FLEX I/O 1797 FLEX Ex I/O	1794 FLEX I/O 1797 FLEX Ex I/O
simple motion	stepper servo via DeviceNet analog ac drive	stepper servo via DeviceNet analog ac drive	stepper servo via DeviceNet analog ac drive	stepper servo via DeviceNet analog ac drive	stepper servo via DeviceNet analog ac drive
integrated motion	SERCOS interface analog interface hydraulic interface SSI interface	not applicable	SERCOS interface analog interface	not applicable	1 full servo 1 feedback axis
mounting and/or installation options	1756 chassis	panel mount DIN rail	none	panel mount DIN rail	embedded in PowerFlex 700S
programming languages	<ul style="list-style-type: none"> relay ladder structured text function block sequential function chart 	<ul style="list-style-type: none"> relay ladder structured text function block sequential function chart 	<ul style="list-style-type: none"> relay ladder structured text function block sequential function chart external routines (Windows DLLs developed using C/C++) 	<ul style="list-style-type: none"> relay ladder structured text function block sequential function chart 	<ul style="list-style-type: none"> relay ladder structured text function block sequential function chart

Logix Platforms

Allen-Bradley Logix platforms provide a single integrated control architecture for discrete, drives, motion, and process control.

The Logix platforms provide a common control engine, programming software environment, and communication support across multiple hardware platforms. All Logix controllers operate with a multitasking, multiprocessing operating system and support the same set of instructions in multiple programming languages. One RSLogix™ 5000 programming software package programs all Logix controllers. And all Logix controllers incorporate the NetLinx Open Network Architecture to communicate via EtherNet/IP, ControlNet, and DeviceNet networks.



ControlLogix System Overview	page 2
Layout the System	page 3
Selecting ControlLogix I/O Modules	page 7
Selecting Motion Control Requirements	page 25
Selecting Network Communications	page 31
Selecting Controllers	page 47
Selecting Chassis	page 63
Selecting Power Supplies	page 67
Selecting Software	page 71
Summary	page 81

ControlLogix System Overview

What's New in Version 13:

- 1756-IB16ISOE and 1756-IH16ISOE modules to record sequence of events
- 1756-IG16 and 1756-OG16 TTL I/O modules
- 1756-IA32 high-density, ac input module
- 1756-EWEB enhanced web server module
- 1756-M03SE 3-axes SERCOS module and 1756-L60M03SE controller with embedded SERCOS interface
- 1756-M02AS SSI feedback motion module
- redundant controller systems now support two 1756-L55 controllers or one 1756-L6x controller
- redundant controller systems now support the 1756-ENBT module
- 1756-PSCA2 adapter module and 1756-CPR2 cable for redundant power supplies

The ControlLogix® system provides sequential, process, motion, and drive control together with communications and state-of-the-art I/O in a small, cost-competitive package. The system is modular, so you can design, build, and modify it efficiently - with significant savings in training and engineering. A simple ControlLogix system consists of a stand-alone controller and I/O modules in a single chassis.

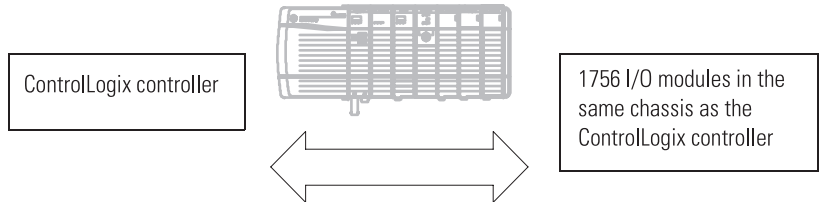

Or use the ControlLogix system as a gateway. Include the communication modules you need for connectivity to other networks. For this use, a controller is not required. The ControlLogix Gateway integrates into existing PLC-based systems so that users with existing networks can send or receive messages to or from other networks. For a more robust system, use:

- multiple controllers in a single chassis
- multiple controllers joined across networks
- I/O in multiple platforms that is distributed in many locations and connected over multiple I/O links

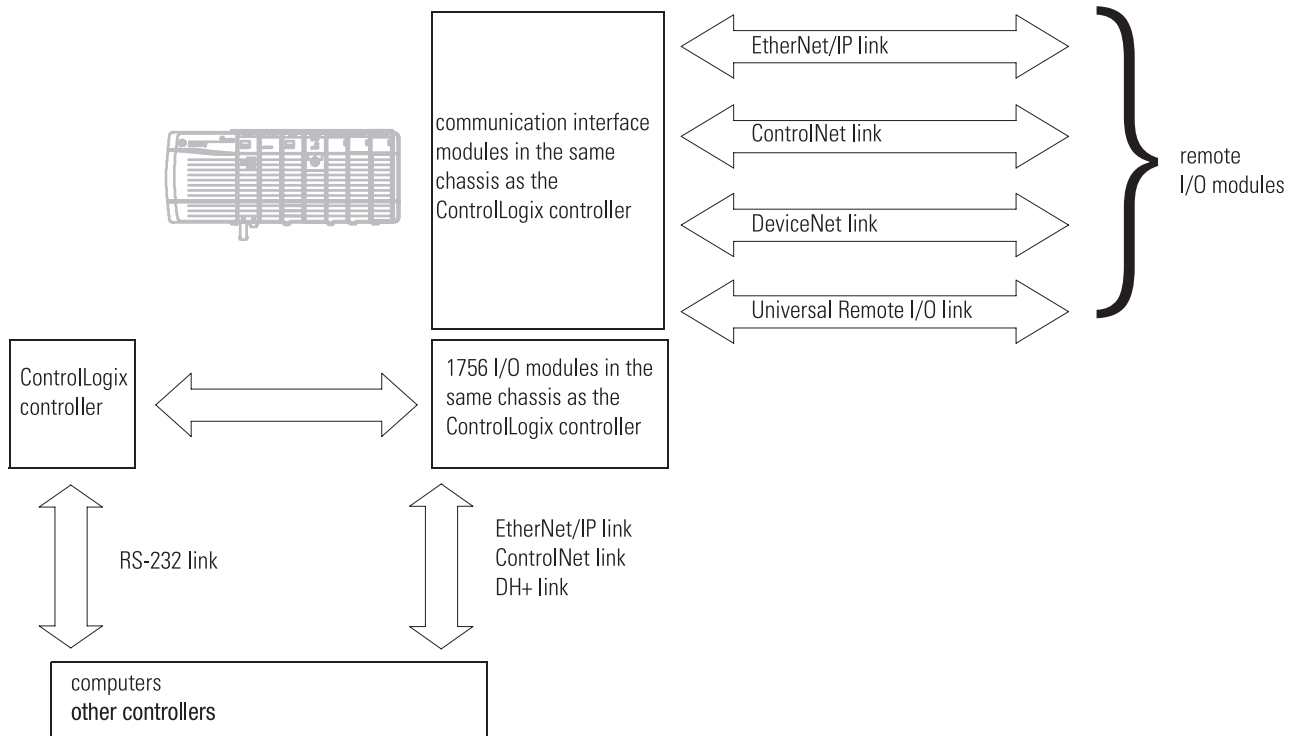

Layout the System

Lay out the system by determining the network configuration and the placement of components in each location. Decide at this time whether each location will have its own controller.

Place each controller's I/O on an isolated network to maximize the performance and to more easily accommodate future network or system configuration changes. If you plan to share I/O, make sure the I/O is on a network that each controller can access.

Assume that Location A and Location B both require a controller and its own I/O. Both controllers interact with time critical information. Panel C does not need a controller and can be a gateway.

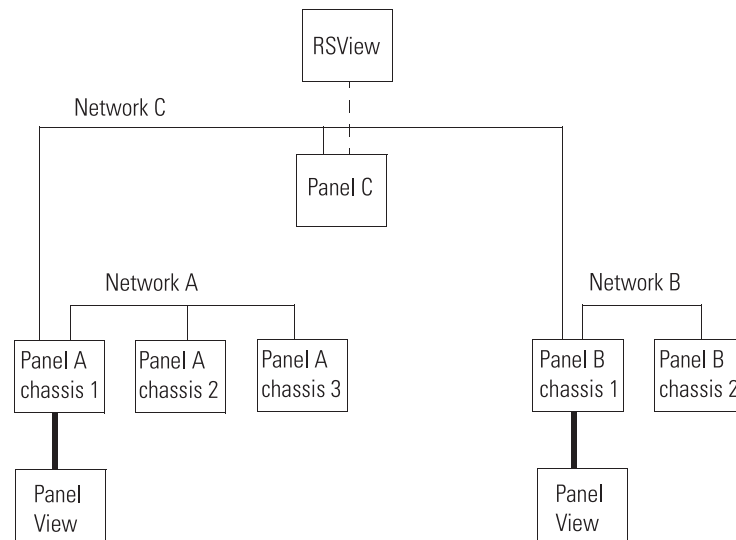

For a ControlLogix controller to control I/O modules, both the controller and the I/O modules must be directly attached to the same network.

I/O Location	Controller in Panel A, Chassis 1	Controller in Panel B, Chassis 1
Panel A, Chassis 1	yes	yes
Panel A, Chassis 2	yes	no
Panel A, Chassis 3	yes	no
Panel B, Chassis 1	yes	yes
Panel B, Chassis 2	no	yes
Panel C, Chassis 1	yes	yes

Evaluate what communications need to occur between controllers. If there is sporadic information that is not time critical, use a message-based network such as an EtherNet/IP (the information portion), Data Highway Plus, or the unscheduled portion of a ControlNet network. If the information is time critical, such as produced/consumed tags between controllers, use a ControlNet or EtherNet/IP network.

Laying out a redundant system

The ControlLogix environment offers different levels of redundancy that you can design into your system. These systems require additional hardware, so plan accordingly. You can design redundant:

- media for ControlNet
- power supplies
- controller chassis

Redundant ControlNet media

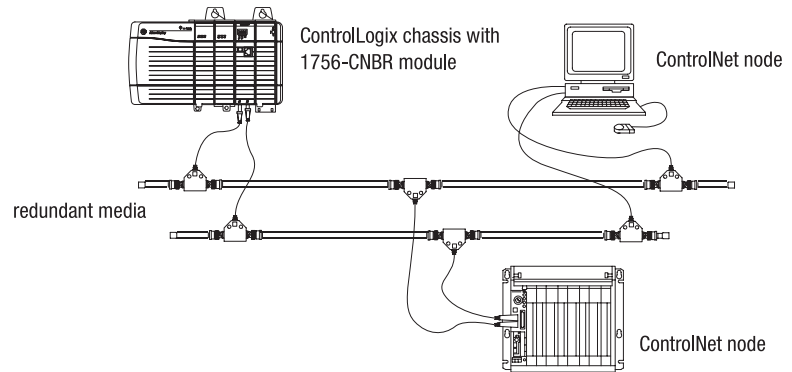

Requires:

- 1756-CNBR ControlNet modules
- two identical ControlNet links

Redundant power supplies

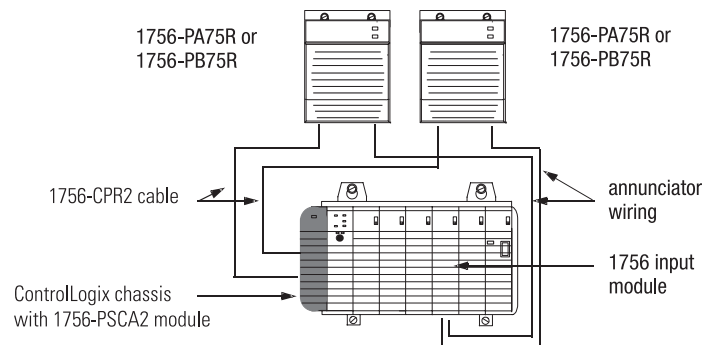

Requires:

- two redundant power supplies, any combination of 1756-PA75R and 1756-PB75R
- 1756-PSCA2 chassis adapter module, in place of the standard power supply
- two 1756-CPR2 cables to connect the power supplies to the 1756-PSCA adapter
- user-supplied annunciator wiring to connect the power supplies to the input modules, if needed

Redundant controller chassis

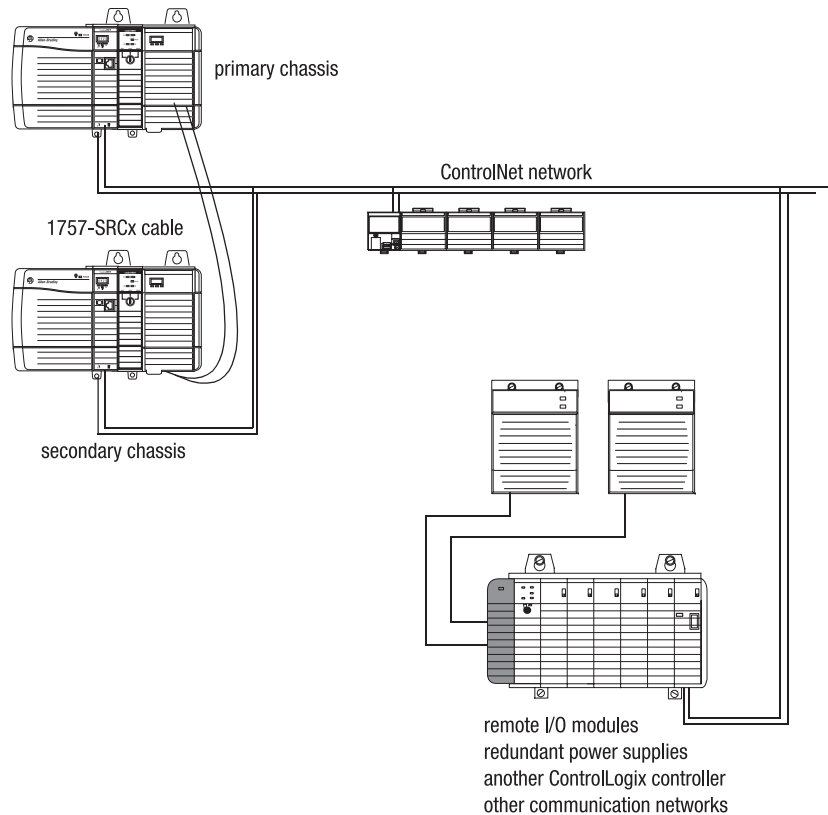

Requires:

- one or two 1756-L55 controllers or one 1769-L6x controller in each redundant chassis (contact your Rockwell Automation representative for the specific firmware revision)
- at least one, but no more than five, 1756-CNB(R) series D, version 5.23 (or greater) communication modules in each redundant chassis
- one 1757-SRM module in each redundant chassis
- the redundant chassis can contain a 1756-ENBT communication module, but no other I/O or communication modules can be in the redundant chassis

All I/O must be remote from the redundant controllers. ControlLogix redundancy works with remote 1756 I/O, FLEX I/O, drives, operator interfaces, or any other devices that can communicate with a ControlLogix controller over a ControlNet link. To connect to other networks, bridge through another ControlLogix chassis (not one of the redundant controller chassis)

Use the following checklist as a guide to completing your own system specification. The inside of the back cover of this selection guide is a worksheet you can use to record your selections.

✓	Step	See
	1 Select I/O devices Use a spreadsheet to record: <ul style="list-style-type: none"> • location of the device • number of points needed • appropriate catalog number • number of points available per module • number of modules 	I/O module specifications page 8 Wiring systems page 14 Placing I/O modules page 23 How I/O modules operate page 24 Selecting controller ownership page 24
	2 Select motion control and drives requirements To the I/O spreadsheet, add the number of required motion modules.	Motion overview page 25 SERCOS interface modules page 27 Analog interface modules page 29
	3 Select communication modules To the I/O spreadsheet, add the number of required communication modules.	Network overview page 31 EtherNet/IP specifications page 33 ControlNet specifications page 35 DeviceNet specifications page 38 DH+/RIO specifications page 39 Foundation Fieldbus specifications page 40 Serial specifications page 40 DH-485 specifications page 42 SynchLink specifications page 43 AutoMax specifications page 45 Accessing the controller remotely page 46
	4 Select controllers Select the appropriate controller based on: <ul style="list-style-type: none"> • required controller tasks • number of I/O points needed • number of communication cards needed • required controller memory 	Controller specifications page 47 Determining memory requirements page 49 Determining battery requirements page 50 Controlling devices page 51 Communicating with other devices page 52 Communicating with drives page 53 How a Logix system uses tasks page 54 How a Logix system uses connections page 57
	5 Select chassis Determine the number of chassis you need.	Chassis specifications page 63
	6 Select power supplies On the module spreadsheet, calculate power requirements.	Power supply specifications page 67
	7 Select software Determine the software products you need to configure and program your application. Based on the system design, determine the software products you need to configure and program your application.	Available software products page 71 Programming software page 72 Communication software page 74 Network configuration software page 75 Emulation software page 76 Training software page 77 Visualization software and products page 79

Step 1 - Select:

- I/O modules - some modules have field-side diagnostics, electronic fusing, or individually isolated inputs/outputs
- a remote terminal block (RTB) or wiring system for each I/O module
- PanelConnect modules and cables if connecting input modules to sensors

Selecting ControlLogix I/O Modules

The ControlLogix architecture provides a wide range of input and output modules to span many applications, from high-speed discrete to process control. The ControlLogix architecture uses producer/consumer technology, which allows input information and output status to be shared among multiple ControlLogix controllers.

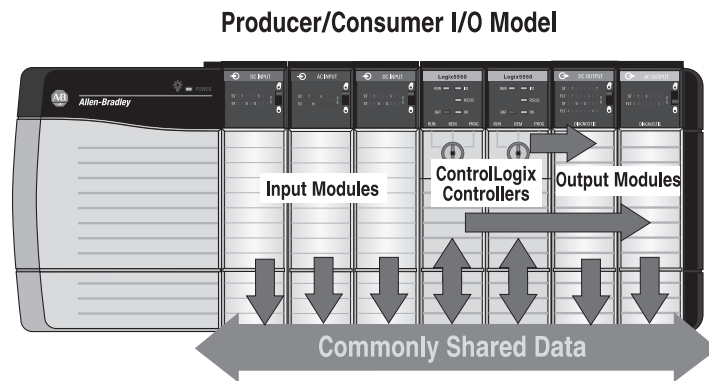

Each ControlLogix I/O module mounts in a ControlLogix chassis and **requires** either a removable terminal block (RTB) or a 1492 interface module (IFM) to connect all field-side wiring. RTBs and IFMs are not included with the I/O modules. They must be ordered separately.

1756 Digital I/O Modules



The 1756 digital I/O modules support:

- wide variety of voltage interface capabilities
- isolated and non-isolated module types
- point-level output fault states
- choice of direct-connect or rack-optimized communications
- field-side diagnostics on select modules

In addition, you can select these types of digital I/O modules:

Digital I/O Type	Description
diagnostic	These modules provide diagnostic features to the point level. These modules have a "D" at the end of the catalog number.
electronic fusing	These modules have internal electronic fusing to prevent too much current from flowing through the module. These modules have an "E" at the end of the catalog number.
individually isolated	These modules have individually isolated inputs or outputs. These modules have an "I" at the end of the catalog number.

Digital ac input modules

Cat. No.	Number of Inputs	Voltage, On-State Input, Nom.	Operating Voltage	Input Delay Time, ON to OFF	Current, On-State Input, Min.	Current, On-State Input, Max.	Current, Off-State Input, Max.	Removable Terminal Block Housing	Backplane Current (mA) at 5V	Backplane Current (mA) at 24V	Power Dissipation, Max.
1756-IA8D	8 diagnostic	120V ac	79...132V ac	Programmable filter: 9 ms & 18 ms	5 mA @ 79V ac	16 mA @ 132V ac	2.5 mA	1756-TBNH 1756-TBSH	100 mA	3 mA	4.5 W @ 60 °C
1756-IA16	16	120V ac	74...132V ac	Programmable filter: 9 ms & 18 ms	5 mA @ 74V ac	13 mA @ 132V ac	2.5 mA	1756-TBNH 1756-TBSH	105 mA	2 mA	5.8 W @ 60 °C
1756-IA16I	16 individually isolated	120V ac	79...132V ac	Programmable filter: 9 ms & 18 ms	5 mA @ 79V ac 47...63Hz	15 mA @ 132V ac, 47...63Hz	2.5 mA	1756-TBCH 1756-TBS6H	125 mA	3 mA	4.9 W @ 60 °C
1756-IA32	32	120V ac	74...132V ac	Programmable filter: 9ms & 18 ms	5 mA @ 74V ac	10 mA @ 132V ac	2.5 mA	1756-TBCH 1756-TBS6H	165 mA	2 mA	6.1 W @ 60°C
1756-IM16I	16 individually isolated	240V ac	159...265V ac	Programmable filter: 9 ms or 18 ms	5 mA @ 159V ac, 60Hz	13 mA @ 265V ac, 60Hz	2.5 mA	1756-TBCH 1756-TBS6H	100 mA	3 mA	5.8 W @ 60 °C
1756-IN16	16	24V ac	10...30V ac	Programmable filter: 9 ms or 18 ms	5 mA @ 10V ac, 60 Hz	1.2 mA @ 30V ac, 60 Hz	2.75 mA	1756-TBNH 1756-TBSH	100 mA	2 mA	5.1 W @ 60 °C

Digital ac output modules

Cat. No.	Number of Outputs	Voltage Category	Operating Voltage	Output Current Rating, per Point, Max.	Output Current Rating, per Module, Max.	Removable Terminal Block Housing	Backplane Current (mA) at 5V	Backplane Current (mA) at 24V	Power Dissipation, Max.
1756-OA8	8	120/240V ac	74...265V ac	2 A @ 60 °C (Linear derating)	5 A @ 30 °C (Linear derating) 4 A @ 60 °C (Linear derating)	1756-TBNH 1756-TBSH	200 mA	2 mA	5.1 W @ 60 °C
1756-OA8D	8 diagnostic	120V ac	74...132V ac	1 A @ 30 °C (Linear derating) 0.5 A @ 60 °C (Linear derating)	8 A @ 30 °C (Linear derating) 4 A @ 60 °C (Linear derating)	1756-TBNH 1756-TBSH	175 mA	250 mA	5.3 W @ 60 °C
1756-OA8E	8 electronic fusing	120V ac	74...132V ac	2 A @ 60 °C	8 A @ 30 °C (Linear derating) 4 A @ 60 °C (Linear derating)	1756-TBNH 1756-TBSH	200 mA	250 mA	5.5 W @ 60 °C
1756-OA16	16	120/240V ac	74...265V ac	0.5 A @ 60 °C	4 A @ 60 °C	1756-TBNH 1756-TBSH	400 mA	2 mA	6.5 W @ 60 °C
1756-OA16I	16 individually isolated	120/240V ac	74...265V ac	2 A @ 30 °C (Linear derating) 1 A @ 60 °C (Linear derating)	5 A @ 30 °C (Linear derating) 4 A @ 60 °C (Linear derating)	1756-TBCH 1756-TBS6H	300 mA	3 mA	5.5 W @ 60 °C
1756-ON8	8	240V ac	10...30V ac	2 A @ 60 °C	5 A @ 30 °C 4 A @ 60 °C (Linear derating)	1756-TBNH 1756-TBSH	200 mA	2 mA	5.1 W @ 60 °C

Digital dc input modules

Cat. No.	Number of Inputs	Voltage, On-State Input, Nom.	Operating Voltage	Input Delay Time, ON to OFF	Current, On-State Input, Min.	Current, On-State Input, Max.	Current, Off-State Input, Max.	Removable Terminal Block Housing	Backplane Current (mA) at 5V	Backplane Current (mA) at 24V	Power Dissipation, Max.
1756-IB16	16	12/24V dc sink	10...31.2V dc	2 ms hardware + filter time (0, 1, 2, 9, or 18 ms)	2.0 mA @ 10V dc	10 mA @ 31.2V dc	1.5 mA	1756-TBNH 1756-TBSH	100 mA	2 mA	5.1 W @ 60 °C
1756-IB16D	16 diagnostic	12/24V dc sink	10...30V dc	4 ms hardware + filter time (0, 1, 2, 9, or 18 ms)	2 mA @ 10V dc	13 mA @ 30V dc	1.5 mA/point	1756-TBCH 1756-TBS6H	150 mA	3 mA	5.8 W @ 60 °C
1756-IB16I	16 individually isolated	12/24V dc sink/source	10...30V dc	4 ms hardware + filter time (0, 1, 2, 9, or 18 ms)	10 mA @ 30 V dc	2 mA @ 10V dc	1.5 mA	1756-TBCH 1756-TBS6H	100 mA	3 mA	5 W @ 60 °C
1756-IB16ISOE*	16 individually isolated; sequence of events	24/48V dc sink/source	10...55V dc	50 µs hardware + filter time (0...50 ms)	5.5 mA @ 55V dc	2 mA @ 10V dc	1.5 mA	1756-TBCH 1756-TBS6H	275 mA	2 mA	5.5 W @ 60 °C
1756-IB32	32	12/24V dc sink	10...31.2V dc	420 µs + filter time (0, 1, 2, 9, or 18 ms)	5.5 mA	2 mA	1.5 mA	1756-TBCH 1756-TBS6H	120 mA	2 mA	6.2 W @ 60 °C
1756-IC16	16	48V dc sink	30...60V dc	4 ms hardware + filter time (0, 1, 2, 9, or 18 ms)	7 mA @ 60V dc	2 mA @ 30V dc	1.5 mA	1756-TBNH 1756-TBSH	100 mA	3 mA	5.2 W @ 60 °C
1756-IG16	16 (8 points/common)	5V dc TTL source	4.5...5.5V dc	.25 ms hardware + filter time (0, 1, 2, 9, or 18 ms)	—	4.1 mA @ 5V dc	4.1 mA	1756-TBNH 1756-TBSH	110 mA	2 mA	1.4 W @ 60 °C
1756-IH16I	16 individually isolated	125V dc sink/source	90...146V dc	6 ms hardware + filter time (0, 1, 2, 9, or 18 ms)	1 mA @ 90V dc	3 mA @ 146V dc	0.8 mA	1756-TBCH 1756-TBS6H	125 mA	3 mA	5 W @ 60 °C
1756-IH16ISOE*	16 individually isolated; sequence of events	125V dc sink/source	90...140V dc	75 µs hardware + filter time (0...50 ms)	1.15 mA @ 90V dc	1.85 mA @ 140V dc	0.3 mA	1756-TBCH 1756-TBS6H	275 mA	2 mA	5.5 W @ 60 °C
1756-IV16	16	12/24V dc source	10...30V dc	2 ms hardware + filter time (0, 1, 2, 9, or 18 ms)	2.0 mA @ 10V dc	10 mA @ 30V dc	1.5 mA	1756-TBNH 1756-TBSH	110 mA	2 mA	5.41 W @ 60 °C
1756-IV32	32	12/24V dc source	10...30V dc	2 ms hardware + filter time (0, 1, 2, 9, or 18 ms)	3.5 mA @ 30V dc	2 mA @ 10V dc	1.5 mA	1756-TBCH 1756-TBS6H	120 mA	2 mA	4.1 W @ 60 °C

*If you use 1756-IB16ISOE or 1756-IH16ISOE modules in a remote rack, you must use a 1756-SYNCH SynchLink module to coordinate system time.

Digital dc output modules

Cat. No.	Number of Outputs	Voltage Category	Operating Voltage	Output Current Rating, per Point, Max.	Output Current Rating, per Module, Max.	Removable Terminal Block Housing	Backplane Current (mA) at 5V	Backplane Current (mA) at 24V	Power Dissipation, Max.
1756-OB8	8	12/24V dc source	10...30V dc	2.0 A @ 60 °C	8.0 A @ 60 °C	1756-TBNH 1756-TBSH	165 mA	2 mA	2.5 W @ 60 °C
1756-OB8EI	8 electronically fused, individually isolated	12/24V dc sink/source	10...30V dc	2 A @ 60 °C	16.0 A @ 55 °C (Linear derating) 10.0 A @ 60 °C	1756-TBCH 1756-TBS6H	250 mA	2 mA	4.7 W @ 60 °C
1756-OB16D	16 diagnostic	24V dc source	19.2...30V dc	2 A @ 30 °C (Linear derating) 1 A @ 60 °C (Linear derating)	8 A @ 30 °C (Linear derating) 4 A @ 60 °C (Linear derating)	1756-TBCH 1756-TBS6H	250 mA	140 mA	3.3 W @ 60 °C
1756-OB16E	16 electronically fused	12/24V dc source	10...31.2V dc	1 A @ 60 °C	8 A @ 60 °C	1756-TBNH 1756-TBSH	250 mA	2 mA	4.1 W @ 60 °C
1756-OB16I	16 individually isolated	12/24V dc sink/source	10...30V dc	2 A @ 30 °C (Linear derating) 1 A @ 60 °C (Linear derating)	8 A @ 30 °C (Linear derating) 4 A @ 60 °C (Linear derating)	1756-TBCH 1756-TBS6H	350 mA	3 mA	3.6 W @ 60 °C
1756-OB16IS	16 individually isolated; 8 scheduled	12/24V dc sink/source	10...30V dc	2 A @ 30 °C (Linear derating) 1 A @ 60 °C (Linear derating)	8 A @ 30 °C (Linear derating) 4 A @ 60 °C (Linear derating)	1756-TBCH 1756-TBS6H	250 mA	3 mA	3.6 W @ 60 °C
1756-OB32	32	12/24V dc source	10...31.2V dc	0.5 A @ 50 °C (Linear derating) 0.35 A @ 60 °C	16 A @ 50 °C (Linear derating) 10 A @ 60 °C	1756-TBCH 1756-TBS6H	300 mA	2 mA	4.8 W @ 60 °C
1756-OC8	8	48V dc source	30...60V dc	2.0 A @ 60 °C	8.0 A @ 60 °C	1756-TBNH 1756-TBSH	165 mA	2 mA	4.9 W @ 60 °C
1756-OG16	16	5V dc TTL	4.5...5.5V dc	24 mA @ 60 °C	384 mA @ 60 °C	1756-TBNH 1756-TBSH	210 mA	2 mA	1.5 W @ 60 °C
1756-OH8I	8 individually isolated	120V dc sink/source	90...146V dc	2 A @ 60 °C	8 A @ 60 °C	1756-TBCH 1756-TBS6H	210 mA	2 mA	3.3 W @ 60 °C
1756-OV16E	16 electronically fused	12/24V dc sink	10...30V dc	1 A @ 60 °C	8 A @ 60 °C	1756-TBNH 1756-TBSH	210 mA	2 mA	6.72 W @ 60 °C
1756-OV32E	32 electronically fused	12/24V dc sink	10...30V dc	0.5 A @ 50 °C (Linear derating) 0.35 A @ 60 °C	16.0 A @ 50 °C (Linear derating) 10.0 A @ 60 °C	1756-TBCH 1756-TBS6H	390 mA	2 mA	5.88 W @ 60 °C

Digital contact output modules

Cat. No.	Number of Outputs	Output Delay Time, ON to OFF, Max.	Type of Contact Output	Operating Voltage	Output Current	Removable Terminal Block Housing	Backplane Current (mA) at 5V	Backplane Current (mA) at 24V	Power Dissipation, Max.
1756-OW16I	16 individually isolated	10 ms	16 N.O.	10...265V ac 5...150V dc	2 A @ 5...30V dc 0.5 A @ 48V dc 0.25 A @ 125V dc 2 A @ 125/240V ac	1756-TBCH 1756-TBS6H	150 mA	150 mA	4.5 W @ 60 °C
1756-OX8I	8 individually isolated	13 ms	1 set of form-C contacts for each output	10...265V ac 5...150V dc	2 A @ 5...30V dc 0.5 A @ 48V dc 0.25 A @ 125V dc 2 A @ 125/240V ac	1756-TBCH 1756-TBS6H	100 mA	100 mA	3.1 W @ 60 °C

1756 Analog I/O Modules

The 1756 analog I/O modules support:

- on-board data alarming
- scaling to engineering units
- real-time channel sampling
- IEEE 32-bit floating point or 16-bit integer data formats

Cat. No.	Number of Inputs	Number of Outputs	Input Resolution, Bits	Sensors Supported	Removable Terminal Block Housing	Backplane Current (mA) at 5V	Backplane Current (mA) at 24V	Power Dissipation, Max.
1756-IF8	8 single-ended, 4 differential, 2 high-speed differential	—	±10.25V 0...5.125V 0...10.25V	—	1756-TBCH 1756-TBS6H	150 mA	40 mA	1.73 W - Voltage 2.33 W - Current
1756-IF6CIS	6 isolated, current sourcing	—	0...21mA Range	—	1756-TBNH 1756-TBSH	250 mA	275 mA	5.1 W @ 60 °C
1756-IF6I	6 isolated	—	±10.5V 0...5.25V 0...10.5V	—	1756-TBNH 1756-TBSH	250 mA	100 mA	3.7 W - Voltage 4.3 W - Current
1756-IF16	8 differential, 4 high-speed differential, 16 single-ended	—	±10.25V 0...5.125V 0...10.25V	—	1756-TBCH 1756-TBS6H	150 mA	65 mA	2.3 W - Voltage 3.9 W - Current
1756-IF4FXOF2F	4 high-speed, sub-millisecond, differential	2 high-speed voltage or current	Inputs ±10.5V 0...5.25V 0...10.5V Outputs ±10.5V	—	1756-TBCH 1756-TBS6H	375 mA	100 mA	4.3 W - Voltage 4.7 W - Current
1756-IR6I	6 isolated RTD	—	100, 200, 500, 1000Ω Platinum, alpha=385 100, 200, 500, 1000Ω Platinum, alpha=3916 120Ω Nickel, alpha=672 100, 120, 200, 500Ω Nickel, alpha=618 10Ω Copper	Resistance 4...4020 Ω 100, 200, 500, 1000 Ω Platinum, alpha = 385 100, 200, 500, 1000 Ω Platinum, alpha = 3916 120 Ω Nickel, alpha = 672 100, 120, 200, 500 Ω Nickel, alpha = 618 10 Ω Copper	1756-TBNH 1756-TBSH	250 mA	125 mA	4.3 W
1756-IT6I	6 isolated thermocouple 1 CJC	—	-12 mV... +78 mV -12 mV... +38 mV	B, E, J, K, R, S, T, N, C	1756-TBNH 1756-TBSH	250 mA	125 mA	4.3 W
1756-IT6I2	6 isolated thermocouple 2 CJC	—	-12 mV... +78 mV -12 mV... +38 mV	B, E, J, K, R, S, T, N, C, L, D	1756-TBNH 1756-TBSH	200 mA	120 mA	3.9 W
1756-OF4	—	4 voltage or current	—	—	1756-TBNH 1756-TBSH	150 mA	120 mA	3.25 W - 4 channel current
1756-OF6CI	—	6 isolated	—	—	1756-TBNH 1756-TBSH	250 mA	300 mA†	5.5 W (0...550 Ω loads) 6.1 W (551...1000 Ω loads)
1756-OF6VI	—	6 isolated	—	—	1756-TBNH 1756-TBSH	250 mA	175 mA	4.85 W
1756-OF8	—	8 voltage or current	—	—	1756-TBNH 1756-TBSH	150 mA	210 mA	4.92 W - 4 channel current

1756 Specialty I/O Modules

1756-CFM configurable flow meter

The 1756-CFM module provides totalizer mode for metering applications, or high-speed frequency measurements for speed or rate control applications, on two channels connected to flowmeters. Both Fill and Prover functions are supported within resettable or nonresettable totalizer mode. A 12-segment K-factor correction table makes it easy to scale any turbine flowmeter and AGA 7 compensation is available.

The module supports two configurable outputs that can be connected to one or both channels and can be triggered on:

- flow or frequency
- acceleration
- full flow state
- trickle flow state
- prover run state
- prover range state

The module interfaces devices such as:

- magnetic pickup flow meters
- 4-40V dc pulses (TTL compatible)
- proximity probes

Cat. No.	Mode of Operation	Number of Inputs per Channel	Voltage, Flowmeter Input	Removable Terminal Block Housing	Backplane Current (mA) at 5V	Backplane Current (mA) at 24V	Power Dissipation, Max.
1756-CFM	Totalizer fill and prover High-Resolution 100 kHz max. Frequency 0.0005 Hz resolution	2 – Flowmeter (F) Input – used for all modes 2 – Gate Input – used in Totalizer Mode for Prover/Store Count	± 30V - Selectable input thresholds of 50 mV, 1.3V & 4V; ± 30V peak unterminated open circuit voltage – Magnetic Pickup TTL Compatible – Input Voltage greater than 1.3V dc is Logic 1 and - 0.7V dc... 1.3V dc is Logic 0 12...24V dc powered preamp output - 4V dc threshold	1756-TBNH 1756-TBSH	300 mA	6 mA	6 W @ 60°C

1756-HSC high speed counter

The 1756-HSC module provides 4 high-speed, output-switching, ON-OFF windows. The module uses pulses for counting and frequency. The module interfaces with pulse devices and encoders, such as:

- photoswitch series 10,000 photoelectric sensors
- bulletin 872 3-wire DC proximity sensors
- bulletin 845 incremental encoders

The 1756-HSC module can update data every 2ms. The module is most effective when you use a single sensor for each of the two channels on the module. If necessary, you can connect a single sensor to multiple channels or modules.

Cat. No.	Mode of Operation	Number of Counters	Inputs per Counter	Count Range	Number of Outputs	Removable Terminal Block Housing	Backplane Current (mA) at 5V	Backplane Current (mA) at 24V	Power Dissipation, Max.
1756-HSC	Counter - 1 MHz max. Rate Measurement - 500 kHz max. Encoder - 250 kHz max. Debounce filter - 70 Hz max.	2	3 (A, B, Z for Gate/Reset)	0...16, 777, 214	4	1756-TBCH 1756-TBS6H	300 mA	3 mA	5.6 W @ 60°C

1756-PLS programmable limit switch

The 1756-PLS module supports enhanced packaging applications where you require:

- deterministic module operation for operations up to 1500 parts per minute (PPM)
- detection of 1.08 degrees of rotation at 1800 RPM
- fast switching of ON-OFF windows
- multi-turn capabilities using resolvers
- direct drive on most pneumatic solenoid or glue guns

The module accepts any R3-style resolver, such as the bulletin 846 resolvers. The module provides excitation to the resolver at 5K Hz @ 7.0V ac and directly connects to the sine and cosine outputs of the resolver.

Cat. No.	Mode of Operation	Number of Inputs	Number of Outputs	Removable Terminal Block Housing	Backplane Current (mA) at 5V	Backplane Current (mA) at 24V	Power Dissipation, Max.
1756-PLS	Requires 3 contiguous slots in chassis	16	16	Requires 3 RTBs 1756-TBNH or 1756-TBSH	1000 mA	125 mA	25.7 W @ 30 °C 21.3 W @ 60 °C

1756 Removable Terminal Blocks



Removable terminal blocks (RTBs) provide a flexible interconnection between your plant wiring and 1756 I/O modules. The RTB plugs into the front of the I/O module. The type of module determines which RTB you need. You choose screw-clamp or spring-clamp RTBs.

RTBs are not shipped with I/O modules. You must order them separately. The standard housing on the front of the wiring arm is not deep enough for 14 AWG wiring. If you plan to use 14 AWG wiring, also order the extended housing.

Cat. No.	Description	Weight
1756-TBNH	screw-clamp with 20-pin connection	0.1 kg (0.3 lb)
1756-TBSH	spring-clamp with 20-pin connection	0.1 kg (0.3 lb)
1756-TBCH	screw-clamp with 36-pin connection	0.1 kg (0.3 lb)
1756-TBS6H	spring-clamp with 36-pin connection	0.1 kg (0.3 lb)
1756-TBE	extended housing; required for additional wiring space if using 14 AWG wiring	0.05 kg (0.1 lb)

1492 Wiring Systems



As an alternative to buying RTBs and connecting the wires yourself, you can buy a wiring system of:

- interface modules (IFMs) that mount on DIN rails provide the output terminal blocks for the I/O module. Use the IFMs with the pre-wired cables that match the I/O module to the interface module.
- I/O-module-ready cables. One end of the cable assembly is an RTB that plugs into the front of the I/O module. The other end has individually color-coded conductors that connect to a standard terminal block.

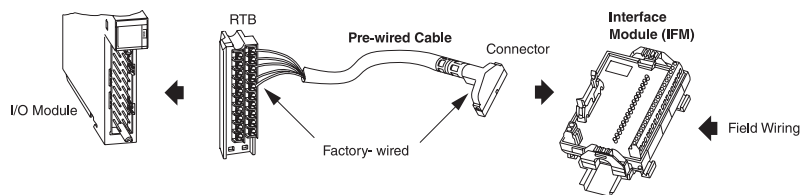

Feed through IFMs for 20-pin 1756 digital I/O modules

Cat. No.	Description	IA8D	IA16	IB16	IC16	IN16	OA8	OA8D	OA8E	OA16	OA16E	OB8	OB16E	OC8	ON8
1492-IFM20F	standard	U	X	X	X	X	U	U	U	X		U	X	U	U
1492-IFM20FN	narrow standard	U	X	X	X	X	U	U	U	X		U	X	U	U
1492-IFM20F-2	extra terminals	U	X	X	X	X	U	U	U	X		U	X	U	U
1492-IFM20F-3	3-wire sensor type input devices		X	X	X	X									
1492-XIMF-2	feed through expander with eight feed-through channels*									X			X		

Find the column for the digital I/O module. Follow the column down to see what digital IFMs are compatible with the I/O module as indicated by a letter code. When you select the IFM, use the letter code from this chart to find the compatible cable in the following table for digital pre-wired cabled. The letter code must match the last character of the catalog number for the cable.

*One expander module is connected to a master to provide a total of 16 outputs. An extender cable is included with each expander to connect it to the master.

LED indicating IFMs for 20-pin 1756 digital I/O modules

Cat. No.	Description	IA8D	IA16	IB16	IC16	IN16	OA8	OA8D	OA8E	OA16	OA16E	OB8	OB16E	OC8	ON8
1492-IFM20D24	standard with 24V ac/dc LEDs			X		X							X		
1492-IFM20D24N	narrow standard with 24V ac/dc LEDs			X		X							X		
1492-IFM20D120	standard with 120V ac LEDs	U	X												
1492-IFM20D120N	narrow standard with 120V ac/dc LEDs	U	X							X					
1492-IFM20D24-2	24V ac/dc LEDs and extra terminals for outputs												X		
1492-IFM20D24A-2	24V ac/dc LEDs and extra terminals for inputs			X		X									
1492-IFM20D120-2	120V ac/dc LEDs and extra terminals for outputs									X					
1492-IFM20D120A-2	120V ac LEDs and extra terminals for inputs	U	X												
1492-IFM20D24-3	3-wire sensor with 24V ac/dc LEDs			X		X									
1492-IFM20DS24-4	isolated with 24/48V ac/dc LEDs and 4 terminals for outputs											W		W	W
1492-IFM20DS120-4	isolated with 120V ac LEDs and 4 terminals for outputs						W	V	V						
1492-IFM20D240-2	240V ac LEDs and extra terminals for outputs														
1492-IFM20D240A-2	240V ac LEDs and extra terminals for inputs														

Find the column for the digital I/O module. Follow the column down to see what digital IFMs are compatible with the I/O module as indicated by a letter code. When you select the IFM, use the letter code from this chart to find the compatible cable in the following table for digital pre-wired cabled. The letter code must match the last character of the catalog number for the cable.

Fusible IFMs for 20-pin 1756 digital I/O modules

Cat. No.	Description	IA8D	IA16	IB16	IC16	IN16	OA8	OA8D	OA8E	OA16	OA16E	OB8	OB16E	OC8	ON8
1492-IFM20F-F-2	extra terminals for outputs									X			X		
1492-IFM20F-F24-2	extra terminals with 24V ac/dc blown fuse indicators for outputs												X		
1492-IFM20F-F120-2	extra terminals with 120V ac blown fuse indicators for outputs									X					
1492-IFM20F-F240-2	extra terminals with 240V ac blown fuse indicators for outputs									X					
1492-IFM20F-F24A-2	extra terminals with 24V ac/dc blown fuse indicators for inputs			X		X									
1492-IFM20F-F120A-2	extra terminals with 120V ac blown fuse indicators for inputs		X												
1492-IFM20F-FS-2	isolated with extra terminals for outputs						W	V	V			W		W	W
1492-IFM20F-FS24-2	isolated with extra terminals and 24V ac/dc blown fuse indicators for outputs											W		W	W
1492-IFM20F-FS24A-4	isolated with 4 terminals and 24V ac/dc blown fuse indicators for inputs														
1492-IFM20F-FS120-2	isolated with extra terminals with 120V ac blown fuse indicators for outputs						W	V	V						
1492-IFM20F-FS120-4	isolated with 4 terminals with 120V ac blown fuse indicators for outputs						W	V	V						
1492-IFM20F-FS120A-4	isolated with 4 terminals with 120V ac blown fuse indicators for inputs	U													
1492-IFM20F-FS240-4	isolated with 4 terminals with 240V ac blown fuse indicators for outputs						W								
1492-XIMF-F24-2	expander with eight 24V dc channels with blown fuse indicators*												X		
1492-XIMF-F120-2	expander with eight 120V ac channels with blown fuse indicators*									X					

Find the column for the digital I/O module. Follow the column down to see what digital IFMs are compatible with the I/O module as indicated by a letter code. When you select the IFM, use the letter code from this chart to find the compatible cable in the following table for digital pre-wired cabled. The letter code must match the last character of the catalog number for the cable.

*One expander module is connected to a master to provide a total of 16 outputs. An extender cable is included with each expander to connect it to the master.

Relay IFMs for 20-pin 1756 digital I/O modules

Cat. No.	Description	IA8D	IA16	IB16	IC16	IN16	OA8	OA8D	OA8E	OA16	OA16E	OB8	OB16E	OC8	ON8
1492-XIM2024-8R	20-pin master with eight 24V dc relays												X		
1492-XIM2024-8R	20-pin master with eight 24V dc relays										X				
1492-XIM24-8R	expander with eight 24V dc relays*												X		
1492-XIM120-8R	expander with eight 120V ac relays*									X					

Find the column for the digital I/O module. Follow the column down to see what digital IFMs are compatible with the I/O module as indicated by a letter code. When you select the IFM, use the letter code from this chart to find the compatible cable in the following table for digital pre-wired cabled. The letter code must match the last character of the catalog number for the cable.

*One expander module is connected to a master to provide a total of 16 outputs. An extender cable is included with each expander to connect it to the master.

Feed through IFMs for 36-pin 1756 digital I/O modules

Cat. No.	Description	IA16I	IB16D	IB16I	IB32	IH16I	IM16I	OA16I	OB8EI	OB16D	OB16E	OB16I	OB32	OH8I	OW16I	OX8I
1492-IFM40F	standard	Y	Y	Y	Z	Y		Y	Y	Y		Y	Z	Y	Y	Y
1492-IFM40F-2	extra terminals		Y		Z					Y			Z			
1492-IFM40F-3	3-wire sensor type input devices				Z											
1492-XIMF-2	expander with eight feed-through channels*												X			

Find the column for the digital I/O module. Follow the column down to see what digital IFMs are compatible with the I/O module as indicated by a letter code. When you select the IFM, use the letter code from this chart to find the compatible cable in the following table for digital pre-wired cabled. The letter code must match the last character of the catalog number for the cable.

*One expander module is connected to a master to provide a total of 16 outputs. An extender cable is included with each expander to connect it to the master.

LED indicating IFMs for 36-pin 1756 digital I/O modules

Cat. No.	Description	IA16I	IB16D	IB16I	IB32	IH16I	IM16I	OA16I	OB8EI	OB16D	OB16E	OB16I	OB32	OH8I	OW16I	OX8I
1492-IFM40D24	standard with 24V ac/dc LEDs				Z								Z			
1492-IFM40D24-2	24V ac/dc LEDs and extra terminals for outputs												Z			
1492-IFM40D24A-2	24V ac/dc LEDs and extra terminals for inputs				Z											
1492-IFM40D120-2	120V ac LEDs and extra terminals for outputs															
1492-IFM40D120A-2	120V ac LEDs and extra terminals for inputs															
1492-IFM40D24-3	3-wire sensor with 24V ac/dc LEDs for inputs				Z											
1492-IFM40DS24-4	isolated with 24/48V ac/dc LEDs and 4 terminals per output								Y	Y		Y			Y	Y
1492-IFM40DS24A-4	isolated with 24/48V ac/dc LEDs and 4 terminals per input		Y	Y												
1492-IFM40DS120-4	isolated with 120V ac LEDs and 4 terminals per output							Y							Y	Y
1492-IFM40DS120A-4	isolated with 120V ac LEDs and 4 terminals per input	Y														
1492-IFM40DS240A-4	isolated with 240V ac LEDs and 4 terminals per output						Y									

Find the column for the digital I/O module. Follow the column down to see what digital IFMs are compatible with the I/O module as indicated by a letter code. When you select the IFM, use the letter code from this chart to find the compatible cable in the following table for digital pre-wired cabled. The letter code must match the last character of the catalog number for the cable.

Fusible IFMs for 36-pin 1756 digital I/O modules

Cat. No.	Description	IA16I	IB16D	IB16I	IB32	IH16I	IM16I	OA16I	OB8EI	OB16D	OB16E	OB16I	OB32	OH8I	OW16I	OX8I
1492-IFM40F-F-2	extra terminals for outputs												Z			
1492-IFM40F-F24-2	extra terminals with 24V ac/dc blown fuse indicators for outputs												Z			
1492-IFM40F-F120-2	extra terminals with 120V ac blown fuse indicators for outputs															
1492-IFM40F-FS-2	isolated with extra terminals for outputs							Y	Y	Y		Y		Y	Y	Y
1492-IFM40F-FS24-2	isolated with extra terminals and 24V ac/dc blown fuse indicators for outputs								Y	Y		Y			Y	Y
1492-IFM40F-FS24-4	isolated with 24V ac/dc blown fuse indicators and 4 terminals per output								Y	Y		Y			Y	Y
1492-IFM40F-FS120-2	isolated with extra terminals and 120V ac blown fuse indicators for outputs							Y						Y	Y	Y
1492-IFM40F-FS120-4	isolated with 120V ac blown fuse indicators and 4 terminals per output							Y							Y	Y
1492-IFM40F-FS240-4	isolated with 240V ac blown fuse indicators and 4 terminals per output							Y							Y	Y
1492-IFM40F-FS24A-4	isolated with 24V ac/dc blown fuse indicators and 4 terminals per input		Y	Y												
1492-IFM40F-FS120A-4	isolated with 120V ac blown fuse indicators and 4 terminals per input	Y				Y										
1492-XIMF-F24-2	fusible expander with eight 24V dc channels with blown fuse indicators*												X			
1492-XIMF-F120-2	fusible expander with eight 120V ac channels with blown fuse indicators*															

Find the column for the digital I/O module. Follow the column down to see what digital IFMs are compatible with the I/O module as indicated by a letter code. When you select the IFM, use the letter code from this chart to find the compatible cable in the following table for digital pre-wired cabled. The letter code must match the last character of the catalog number for the cable.

*One expander module is connected to a master to provide a total of 16 outputs. An extender cable is included with each expander to connect it to the master.

Relay IFMs for 36-pin 1756 digital I/O modules

Cat. No.	Description	IA16I	IB16D	IB16I	IB32	IH16I	IM16I	OA16I	OB8EI	OB16D	OB16E	OB16I	OB32	OH8I	OW16I	OX8I
1492-XIM4024-8R	40-pin master with eight 24V dc relays												Z			
1492-XIM4024-16R	40-pin master with sixteen 24V dc relays												Z			
1492-XIM24-8R	expander with eight 24V dc relays*										X					
1492-XIM120-8R	expander with eight 120V ac relays*															

Find the column for the digital I/O module. Follow the column down to see what digital IFMs are compatible with the I/O module as indicated by a letter code. When you select the IFM, use the letter code from this chart to find the compatible cable in the following table for digital pre-wired cabled. The letter code must match the last character of the catalog number for the cable.

*One expander module is connected to a master to provide a total of 16 outputs. An extender cable is included with each expander to connect it to the master.

Pre-wired cables for digital I/O modules

Cat. No.*	Number of Conductors	Conductor Size	Nominal Outer Diameter	RTB at the I/O Module End
1492-CABLEXU	20	22 AWG	9.0 mm (0.36 in)	1756-TBNH
1492-CABLEXV	20	22 AWG	9.0 mm (0.36 in)	1756-TBNH
1492-CABLEXW	20	22 AWG	9.0 mm (0.36 in)	1756-TBNH
1492-CABLEXZ	20	22 AWG	9.0 mm (0.36 in)	1756-TBNH
1492-CABLEXY	40	22 AWG	11.7 mm (0.46 in)	1756-TBCH
1492-CABLEXZ	40	22 AWG	11.7 mm (0.46 in)	1756-TBCH

*Cables are available in lengths of 0.5m, 1.0m, 2.5m, and 5.0m. To order, insert the code for the desired cable length into the catalog number in place of the x: 005=0.5m, 010=1.0m, 025=2.5m, 050=5m.

I/O-module-ready cables for digital I/O modules

Cat. No.*	Number of Conductors	Conductor Size	Nominal Outer Diameter	RTB at the I/O Module End
1492-CABLEXTBNH	20	18 AWG	11.4 mm (0.45 in)	1756-TBNH
1492-CABLEXTBCH	40†	18 AWG	14.1 mm (0.55 in)	1756-TBCH

*Cables are available in lengths of 0.5m, 1.0m, 2.5m, and 5.0m. To order, insert the code for the desired cable length into the catalog number in place of the x: 005=0.5m, 010=1.0m, 025=2.5m, 050=5m. Build-to-order cable lengths are also available.

†Four conductors are not connected to the RTB.

For example, a 1756-OB32 that requires LEDs and extra terminals uses:

- 1492-IFM40D24-2 interface module
- 1492-ACABLEXZ cable (replace x with the appropriate length)

AIFMs for 1756 analog input modules

Cat. No.	Type of AIFM	Description	IF6I	IF6I	IF8 single-end		IF8 differential		IF16 single-end		IF16 differential		IR6I	IT6I
			current	voltage	voltage	current	voltage	current	voltage	current	voltage	current		
1492-AIFM4-3	feed through	4 channels with 3 terminals/c hannel												
1492-AIFM6S-3	feed through	6 channels isolated with 3-4 terminals/c hannel	X	Y									Z	
1492-AIFM8-3	feed through	8 channels with 3 terminals/c hannel			TA	TB	TC	TD	UA	UB	UC	UD		
1492-AIFM6TC-3	thermo couple	6 channels with 3 terminals/c hannel												Y
1492-AIFM8-F-5	fusible	8 channels with 5 terminals/c hannel			TA	TB	TC	TD						
1492-AIFM16-F-3	fusible	16 channels with 3 terminals/c hannel							UA	UB	UC	UD		
1492-AIFM16-F-5	fusible	16 channels with 5 terminals/c hannel							UA	UB	UC	UD		

Find the column for the analog I/O module. Follow the column down to see what AIFMs are compatible with the I/O module as indicated by a letter code. When you select the AIFM, use the letter code from this chart to find the compatible cable in the following table for analog pre-wired cable. The letter code must match the last character of the catalog number for the cable.

AIFMs for 1756 analog output modules

Cat. No.	Type of AIFM	Description	IR6I	IT6I	OF4 (voltage)	OF4 (current)	OF6CI	OF6VI	OF8 (voltage)	OF8 (current)
1492-AIFM4-3	feed through	4 channels with 3 terminals/channel			VA	VB				
1492-AIFM6S-3	feed through	6 channels isolated with 3-4 terminals/channel	Z				Y	Y		
1492-AIFM8-3	feed through	8 channels with 3 terminals/channel							WA	WB
1492-AIFM6TC-3	thermocouple	6 channels with 3 terminals/channel		Y						
1492-AIFM8-F-5	fusible	8 channels with 5 terminals/channel								
1492-AIFM16-F-3	fusible	16 channels with 3 terminals/channel								
1492-AIFM16-F-5	fusible	16 channels with 5 terminals/channel								

Find the column for the analog I/O module. Follow the column down to see what AIFMs are compatible with the I/O module as indicated by a letter code. When you select the AIFM, use the letter code from this chart to find the compatible cable in the following table for analog pre-wired cable. The letter code must match the last character of the catalog number for the cable.

AIFMs for 1757 analog I/O modules

Cat. No.	Type of AIFM	Description
1492-AIFMPI-3	fusible	8 input/output channels

The letter code for this AIFM is M. Use the letter code M to find the compatible cable in the following table for analog pre-wired cable. The letter code must match the last character of the catalog number for the cable.

Pre-wired cables for analog I/O modules

Cat. No.*	Number of Conductors†	Conductor Size	Nominal Outer Diameter	RTB at the I/O Module End
1492-ACABLExM	11 twisted pairs	22 AWG	11.5 mm (0.45 in)	1757-PIM
1492-ACABLExX	9 twisted pairs‡	22 AWG	6.8 mm (0.27 in)	1756-TBNH
1492-ACABLExY	9 twisted pairs§	22 AWG	6.8 mm (0.27 in)	1756-TBNH
1492-ACABLExZ	20 conductors¶	22 AWG	8.4 mm (0.33 in)	1756-TBNH
1492-ACABLExTA	20 conductors	22 AWG	8.4 mm (0.33 in)	1756-TBCH
1492-ACABLExTB	20 conductors	22 AWG	8.4 mm (0.33 in)	1756-TBCH
1492-ACABLExTC	5 twisted pairs	22 AWG	8.4 mm (0.33 in)	1756-TBCH
1492-ACABLExTD	5 twisted pairs	22 AWG	8.4 mm (0.33 in)	1756-TBCH
1492-ACABLExUA	20 conductors	22 AWG	8.4 mm (0.33 in)	1756-TBCH
1492-ACABLExUB	20 conductors	22 AWG	8.4 mm (0.33 in)	1756-TBCH
1492-ACABLExUC	9 twisted pairs	22 AWG	6.8 mm (0.27 in)	1756-TBCH
1492-ACABLExUD	9 twisted pairs	22 AWG	6.8 mm (0.27 in)	1756-TBCH
1492-ACABLExVA	20 conductors	22 AWG	8.4 mm (0.33 in)	1756-TBNH
1492-ACABLExVB	20 conductors	22 AWG	8.4 mm (0.33 in)	1756-TBNH
1492-ACABLExWA	9 twisted pairs	22 AWG	6.8 mm (0.27 in)	1756-TBNH
1492-ACABLExWB	9 twisted pairs	22 AWG	6.8 mm (0.27 in)	1756-TBNH

*Cables are available in lengths of 0.5m, 1.0m, 2.5m, and 5.0m. To order, insert the code for the desired cable length into the catalog number in place of the x: 005=0.5m, 010=1.0m, 25=2.5m, 050=5m. Build-to-order cable lengths are also available.

†Each cable for analog I/O has an overall shield with a ring lug on a 200mm (8.87 in) exposed drain wire at the I/O module end of the cable.

‡One pair is not connected to the I/O module connector; two additional pairs are not used.

§Two pairs are not used.

¶One conductor is not connected to the I/O module connector; one additional conductor is not used.

For example, a 1756-IF6I in voltage mode uses:

- 1492-AIFM6S-3 interface module
- 1492-ACABLExY cable (replace x with the appropriate length)

1492 PanelConnect Modules for Connecting Sensors

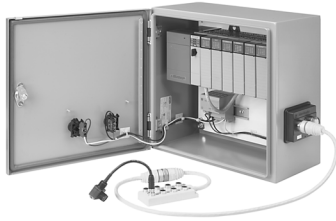

A PanelConnect module and its sensor connection systems lets you connect as many as 16 sensors directly to 16-point input modules using convenient pre-built cables and connectors.

The PanelConnect module mounts on the enclosure and creates the correct seal for the entry of the sensor connections. You do not need to seal the opening where the sensor cables enter the enclosure, create custom connectors, or wire to those custom connectors.

Cat. No.	System Voltage	Connects to These Distribution Boxes	Connector Style	Connectors	LEDs
1492-TPMA1008	ac	Allen-Bradley, Brad Harrison (Daniel Woodhead), Crouse-Hinds, and Lumberg	mini-plus (1 1/8 in.)	10 pin	without
1492-TPMA1207		Allen-Bradley, Brad Harrison (Daniel Woodhead), Crouse-Hinds, and Lumberg		12 pin	with
1492-TPMA2209		Turck	metric M23	12 pin	either with or without
1492-TPMD1004	dc	Allen-Bradley, Brad Harrison (Daniel Woodhead), and Crouse-Hinds	mini-plus (1 1/8 in.)	10 pin	without
1492-TPMD1201		Allen-Bradley		12 pin	with
1492-TPMD1202		Brad Harrison (Daniel Woodhead)		12 pin	with
1492-TPMD1203		Lumberg		12 pin	with
1492-TPMD2205		Turck	metric M23	12 pin	either with or without
1492-TPMD2206		Turck		12 pin	either with or without

You can select these PanelConnect modules and cables, depending on the 16-point input modules in your system:

I/O Module *	1492-TPMA1008	1492-TPMA1207	1492-TPMA2209	1492-TPMD1004	1492-TPMD1201	1492-TPMD1202	1492-TPMD1203	1492-TPMD2205	1492-TPMD2206
1756-IA16	1492-CABLExX	1492-CABLExX	1492-CABLExX						
1756-IB16				1492-CABLExX	1492-CABLExX	1492-CABLExX	1492-CABLExX	1492-CABLExX	1492-CABLExX
1756-IC16				1492-CABLExX				1492-CABLExX	1492-CABLExX
1756-IN16	1492-CABLExX			1492-CABLExX					1492-CABLExX

*Cables are available in lengths of 0.5m, 1.0m, and 5.0m. To order, insert the code for the desired cable length into the catalog number in place of the x: 005=0.5m, 010=1.0m, 050=5m.

Select a patchcord to connect the PanelConnect module to the sensor distribution box, depending on the type of connector:

Cat. No.*	Diameter - mm (in)	Wire Rating	Connector Type
889N-F10AFNU-x	17 (0.67)	16 AWG 600V 7 A	10 pin Mini-Plus (1 18"), straight male
889N-F12AFNU-x	18 (0.71)		12 pin Mini-Plus (1 18"), straight male
889N-F10AFNV-x	17 (0.67)		10 pin Mini-Plus (1 18"), right-angle male
889N-F12AFNV-x	18 (0.71)		12 pin Mini-Plus (1 18"), right-angle male
889N-F10ACNU-x	9 (0.36)	18/22 AWG 300V 5 A	10 pin Mini-Plus (1 18"), straight male
889N-F12ACNU-x	9 (0.36)		12 pin Mini-Plus (1 18"), straight male
889N-F10ACNV-x	9 (0.36)		10 pin Mini-Plus (1 18"), right-angle male
889N-F12ACNV-x	9 (0.36)		12 pin Mini-Plus (1 18"), right-angle male

*Cables are available in lengths of 2m, 3m, 5m, and 10m. To order, insert the code for the desired cable length into the catalog number in place of the x: 2=2m, 3=3m, 5=5m, 10=10m.

Placing ControlLogix I/O Modules

The producer/consumer model multicasts messages. This means that multiple nodes can consume the same data at the same time from a single device. Where you place I/O modules in the control system determines how the modules exchange data.

If the I/O module is:	And you place the module here:	The data exchange method is based on:
digital	local chassis	change of state and / or requested packet interval (cyclic)
	remote chassis	requested packet interval
analog	local chassis	real time sample and / or requested packet interval
	remote chassis	requested packet interval

For a ControlLogix controller to control 1756 I/O, the I/O must be:

- in the same chassis as the controller **or**
- on a ControlNet network that is local to that controller **or**
- on an Ethernet/IP network that is local to that controller

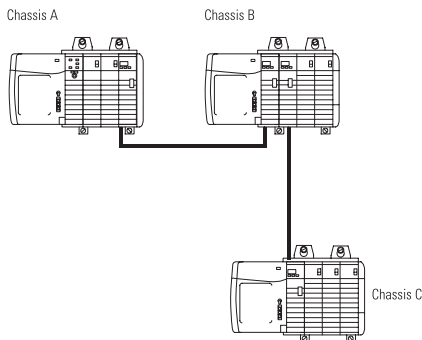

For example, assume that the network links in this example are either ControlNet or Ethernet/IP links. Both links can be the same, or one link can be a ControlNet link and the other can be an Ethernet/IP link. Chassis A can control the 1756 I/O modules in Chassis A and in Chassis B, but not in Chassis C. The ControlLogix controller in Chassis A can only send messages to the devices in Chassis C.

Selecting Controller Ownership

In a Logix system, modules multicast data. This means that multiple devices can receive the same data at the same time from a single device. When you choose a communication format for an I/O module, you have to choose whether to establish an owner or listen-only relationship with the module.

Relationship	Description
owner controller	The controller that creates the primary configuration and communication connection to a module. The owner controller writes configuration data and can establish a connection to the module.
listen-only connection	An I/O connection where another controller owns/provides the configuration data for the I/O module. A controller using a listen-only connection only monitors the module. It does not write configuration data and can only maintain a connection to the I/O module when the owner controller is actively controlling the I/O module.

How ControlLogix Modules Operate

In a ControlLogix system, I/O updates occur asynchronous to the execution of logic. This lets your application receive updated data as soon as possible. If your application needs synchronous I/O updates, use the synchronous copy (CPS) instruction to buffer I/O data at the beginning of each scan.

Module Type	Placement	Operation
digital input	local chassis	<p>The RPI specifies the rate at which a module multicasts its data. The time ranges from 200 microseconds to 750 milliseconds. When the specified time frame elapses, the module will multicast data (also called cyclic data exchange).</p> <p>If a change of state (COS) does not occur within the RPI timeframe, the module multicasts data at the rate specified by the RPI.</p> <p>Because the RPI and COS functions are asynchronous to the logic scan, it is possible for an input to change state during program scan execution. If this is a concern, buffer input data so your logic has a stable copy of data during its scan. Use the Synchronous Copy (CPS) instruction to copy the input data from your input tags to another structure and use the data from that structure.</p>
	remote chassis	<p>The RPI and COS values still define when the module multicasts data within its own chassis, but only the value of the RPI determines when the owner controller receives the data over the network.</p> <p>When an RPI value is specified for an input module in a remote chassis, in addition to instructing the module to multicast data within its own chassis, the RPI also reserves a spot in the stream of data flowing across the control network. The timing of this reserved spot may or may not coincide with the exact value of the RPI, but the owner-controller will receive data at least as often as the specified RPI.</p>
digital output	local chassis	<p>If the module resides in the same chassis as the owner-controller, the module receives the data almost immediately after the owner-controller sends it. Data is sent after all the programs within each task have completed executing.</p>
	remote chassis	<p>If an output module resides in a chassis other than that of the owner-controller (i.e. a remote chassis connected via ControlNet or Ethernet/IP), the owner-controller sends data to the output module only at the RPI rate.</p> <p>The RPI also reserves a spot in the stream of data flowing across the control network. The timing of this reserved spot may or may not coincide with the exact value of the RPI, but the output module receives data at least as often as the specified RPI.</p>
analog input	local chassis	<p>The RTS value specifies when the module scans its channels and multicasts the data (update the input data buffer then multicast). The RPI value specifies when the module multicasts the current contents of the input data buffer without scanning (updating) the channels.</p> <p>The module resets the RPI timer each time an RTS transfer occurs. If the RTS value is less than or equal to the RPI value, each multicast of data from the module has newly updated channel data. The module only multicasts at the RTS rate.</p> <p>If the RTS value is greater than the RPI, the module multicasts at both the RTS rate and the RPI rate.</p>
	remote chassis	<p>The RPI and RTS rates still define when the module multicasts data within its own chassis, but only the RPI value determines when the owner-controller receives the data over the network.</p> <p>The RPI also reserves a spot in the stream of data flowing across the control network. The timing of this reserved spot may or may not coincide with the exact value of the RPI, but the controller receives data at least as often as the specified RPI.</p>
analog output	local chassis	<p>The RPI value specifies when the owner-controller broadcasts output data to the module. If the module resides in the same chassis as the owner-controller, the module receives the data almost immediately after the owner-controller sends it.</p>
	remote chassis	<p>If an output module resides in a chassis other than that of the owner-controller (i.e. a remote chassis connected via ControlNet or Ethernet/IP), the owner-controller sends data to the output module only at the RPI rate.</p> <p>The RPI also reserves a spot in the stream of data flowing across the control network. The timing of this reserved spot may or may not coincide with the exact value of the RPI, but the output module receives data at least as often as the specified RPI.</p>

Step 2 - Select:

- *size the motion application (use Motion Book)*
- *how you want to interface the controller and drives*
- *a SERCOS or analog interface module*
- *associated cable(s)*
- *a removable terminal block (RTB) - only needed for the analog interface modules*
- *select drives, motors, and accessories (use Motion Book)*

Selecting Motion Control Requirements

The Logix approach to motion control employs synchronized, distributed processing and provides a highly-integrated motion solution. Logix integrates sequential and motion control to bring unmatched flexibility to machine design and unprecedented efficiency to the manufacturing floor. RSLogix 5000 Enterprise series software supports a comprehensive set of embedded motion instructions that can be programmed using the relay ladder, structured text, or sequential function chart editors. The embedded motion instructions satisfy a wide range of machine control needs, including independent axis motion, synchronized gearing and camming, and fully-interpolated motion in three dimensions.

The Logix architecture supports motion components that work in a wide variety of machine architectures:

- The Kinetix integrated motion solution uses a SERCOS interface™ module to perform complex, multi-axis, synchronized motion. With a Kinetix system, you reap the full benefit of the integrated architecture because the integration doesn't stop at the controller. This system integrates the drive, the motor, and even the actuator at a lower cost per axis of motion.
- Logix integrated motion using the analog family of servo modules for controlling drives/actuators that do not support the SERCOS interface. The analog family of servo modules provide a ± 10 voltage analog output and can interface with a variety of feedback device types including rotary/linear absolute and incremental.
- Networked motion provides the ability to connect via DeviceNet to a single-axis drive to perform simple, point to point indexing. You need Ultraware™ software for drive and indexing configuration.

Use this selection guide to select the appropriate motion interface. For more information, use:

- Motion Book to size your motion application and to make final component selection. Motion Book is available on The Automation Bookstore (www.theautomationbookstore.com) and the Rockwell Automation motion website (www.ab.com/motion/software/motion_book.html)
- the *Motion Control Selection Guide*, publication GMC-SG001, to verify drive, motor, and accessory specifications

Selecting a Motion Interface

You can communicate directly to a servo drive using a motion interface or over a network.

Communicate directly to a servo drive

The controller can control these servo drives through these motion interfaces:

If your application requires:	Select this motion interface:
<ul style="list-style-type: none"> Rockwell Automation SERCOS interface drives 	<ul style="list-style-type: none"> 1756-M16SE (16 axes) 1756-M08SE (8 axes) 1756-M03SE (3 axes) 1756-L60M03SE (3 axes)
<ul style="list-style-type: none"> analog command signal quadrature feedback 	1756-M02AE
<ul style="list-style-type: none"> analog command signal LDT feedback 	1756-HYD02
<ul style="list-style-type: none"> analog command signal SSI feedback 	1756-M02AS

Communicate over a network

Some servo drives are supported through communication interface modules. The controller can communicate with these servo drives over these networks:

Drives*	EtherNet/IP	ControlNet	DeviceNet	Universal Remote I/O	RS-232 Serial	DH-485
1394 GMC drive and control	no	no	no	yes	yes	yes
2098 Ultra3000 DeviceNet servo drive	no	no	yes	no	no	no
2098 Ultra5000 intelligent positioning	no	no	yes	no	yes	no

*Each drive has different options you order for its supported communication networks. See the appropriate catalog or selection information for a drive to make sure you select the appropriate option when specifying a drive for a specific network.

For more information on drives, motors, and accessories, see the *Motion Control Selection Guide*, publication GMC-SG001.

SERCOS Interface Modules



The SERCOS interface servo modules serve as a link between the ControlLogix platform and intelligent, servo drives. SERCOS is the IEC 61491 Serial Real-time COmmunication System protocol over a fiber optic medium. The SERCOS interface is an open, controller-to-digital drive interface designed for high-speed, real time, serial communications using noise-immune, fiber-optic cables.

The SERCOS interface modules use a single, digital fiber optic link, which eliminates up to 18 discrete wires per axis. Detailed drive status information can be sent from drive to controller and from controller to drive.

The modules are compatible with the RSLogix 5000 motion instructions set (38 motion instructions) and axis configuration utilities. The motion instructions provide a wide range of motion capability, including point-point positioning, gearing, position and time-based camming, and multi-axis linear and circular motion.

The SERCOS interface modules can connect to these servo drives:

- 2094 Kinetix 6000 servo drive
- 2098 Ultra3000 SERCOS servo drive
- 1394C SERCOS drive
- 8720MC spindle

Cat. No.	Number of Axes, per Module, Max.	Number of Axes, per Controller, Max.	Power Dissipation	Backplane Current (mA) at 5V	Backplane Current (mA) at 24V	SERCOS Data Rate
1756-M03SE	3	32	5.0 W	900 mA	2.5 mA	4 Mbits or 8 Mbits per second
1756-L60M03SE*	3 SERCOS axes included 6 axes total with addition of another motion module	32	8.5 W	1960 mA	16.5 mA	
1756-M08SE	8	32	5.0 W	900 mA	2.5 mA	
1756-M16SE	16					

Certifications: UL, CSA (Class 1, Division 2, Group A, B, C, D), CE

*The 1756-L60M03SE is a 1756-L60 ControlLogix controller with an embedded 1756-M03SE SERCOS interface. This is a 2-slot module.

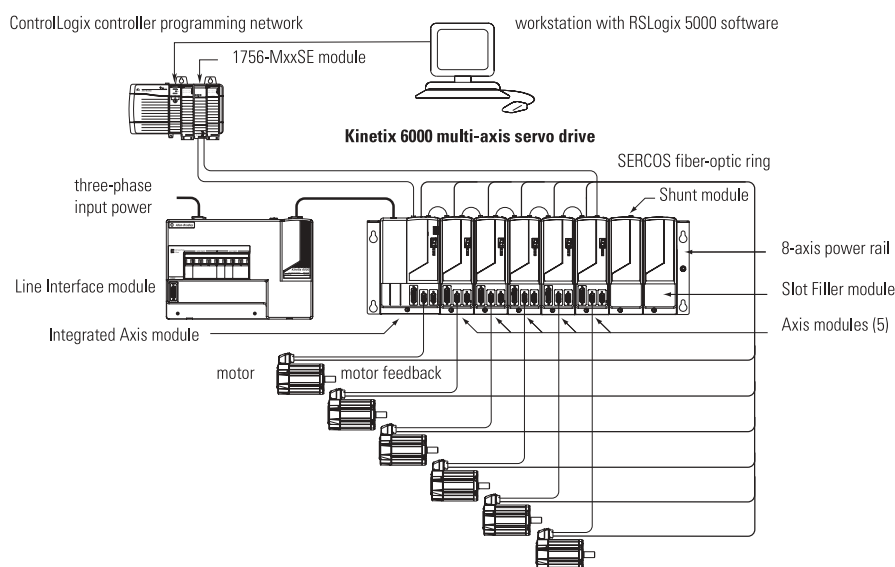

Cables for Use with the SERCOS Interface Modules

Select one of these fiber optic cables to connect the SERCOS interface module to the drive:

Cat. No.	Description
2090-SCEP _{x-x} (no jacket) 2090-SCVP _{x-x} (standard jacket) 2090-SCNP _{x-x} (nylon jacket)	Plastic Fiber Optic Cables* 1000 μm plastic simplex fiber optic cable transmission range of 1-32 meters. Allen-Bradley offers plastic, fiber-optic cable assemblies that come in a variety of jackets: <ul style="list-style-type: none"> • no jacket (Chlorinated Polyethylene) for use inside an electrical cabinet • a standard jacket (Polyvinyl Chloride) for use outside of electrical cabinets • a nylon jacket for use in harsh environments
2090-SCVG _{x-x}	Glass Fiber Optic Cables† 200 μm glass fiber optic cable transmission range of 1-200 meters Allen-Bradley offers glass, fiber-optic cable assemblies that come with a standard jacket (Polyvinyl Chloride) for use in normal environments.

*The x-x determines the length in meters. Specify 0-1 for 0.1m, 0-3 for 0.3m, 1-0 for 1m, 3-0 for 3m, 5-0 for 5m, 8-0 for 8m, 10-0 for 10m, 15-0 for 15m, 20-0 for 20m, 25-5 for 25m, or 32-0 for 32m.

†The x-x determines the length in meters. Specify 1-0 for 1m, 5-0 for 5m, 8-0 for 8m, 10-0 for 10m, 15-0 for 15m, 20-0 for 20m, 25-0 for 25m, 32-0 for 32m, 50-0 for 50m, 100-0 for 100m, 150-0 for 150m, or 200-0 for 200m.

Both the transmitter and receiver connections use a F-SMA standard plug that conforms to the F-SMA screw type connector.

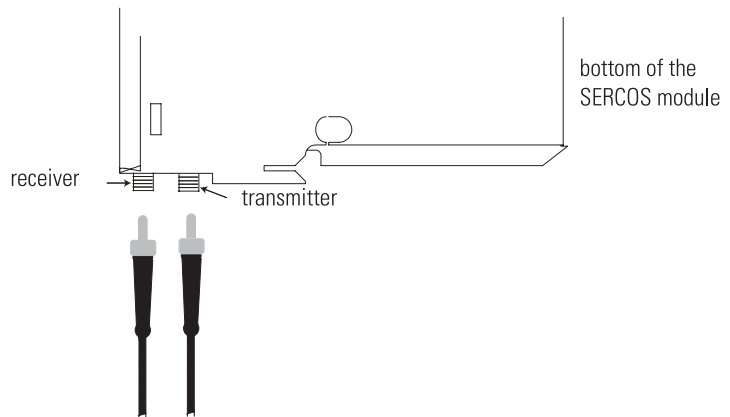

Analog Interface Modules



The ControlLogix family of analog servo modules is a cost effective option for closed- or open-loop motion control of devices that support an analog interface. The analog servo modules provide an ± 10 volt analog output command reference and support a variety of different position feedback devices. As many as two axes can be controlled per module, and multiple modules can be used to provide as many as 32 axes of control per ControlLogix controller.

The modules are compatible with the RSLogix 5000 motion instructions set (38 motion instructions) and axis configuration utilities. The motion instructions provide a wide range of motion capability, including point-point positioning, gearing, position and time-based camming, and multi-axis linear and circular motion.

Select the appropriate analog interface module:

This interface module:	Offers:
1756-M02AE	The 1756-M02AE is a two-axis servo module optimized for control of drives/actuators which require an ± 10 volt velocity or torque reference input. The 1756-M02AE provides a quadrature position feedback output and is compatible with a wide range of quadrature output rotary and linear transducers.
1756-HYD02	The 1756-HYD02 is a two-axis servo module optimized for control of hydraulic actuators which require an ± 10 volt velocity reference input. The 1756-HYD02 provides an LDT feedback input. Typical actuators include hydraulic motors and hydraulic cylinders. The 1756-HYD02 is compatible with a wide range of magnostriptive linear transducers (LDT) feedback devices. Compatible LDTs include: <ul style="list-style-type: none"> • Temposonics II: RPM or DPM • Balluff: BTL-2-L2 or BTL-2-M2 • Santest: GYRP or GYRG • Gemco Quick-Stick II: 951 VP or 951 RS
1756-M02AS	The 1756-M02AS is a two-axis servo module optimized for control of drives/actuators which require an ± 10 volt velocity or torque reference input. The 1756-M02AS provides a Serial Synchronous Input (SSI) position feedback output and is compatible with a wide range of quadrature output rotary and linear transducers. SSI devices are available in many versions: <ul style="list-style-type: none"> • linear absolute and incremental encoders • rotary absolute and incremental encoders • linear absolute glass scales • linear magnostriptive • linear laser distance

Cat. No.	Number of Axes, per Module, Max.	Number of Axes, per Controller, Max.	Power Dissipation	Backplane Current (mA) at 5V	Backplane Current (mA) at 24V	Removable Terminal Block Housing
1756-M02AE	2	32	5.5 W	700 mA	2.5 mA	1756-TBCH 1756-TBS6H*
1756-HYD02			5.5 W	700 mA	2.5 mA	1756-TBCH 1756-TBS6H*
1756-M02AS			5.5 W	700 mA	2.5 mA	1756-TBCH 1756-TBS6H*

Certifications: UL, CSA (Class I, Division 2, Group A, B, C, D), CE
 *Maximum wire size will require the extended depth RTB housing (1756-TBE).

The following example shows a sample configuration using the 1756-HYD02 analog interface module.

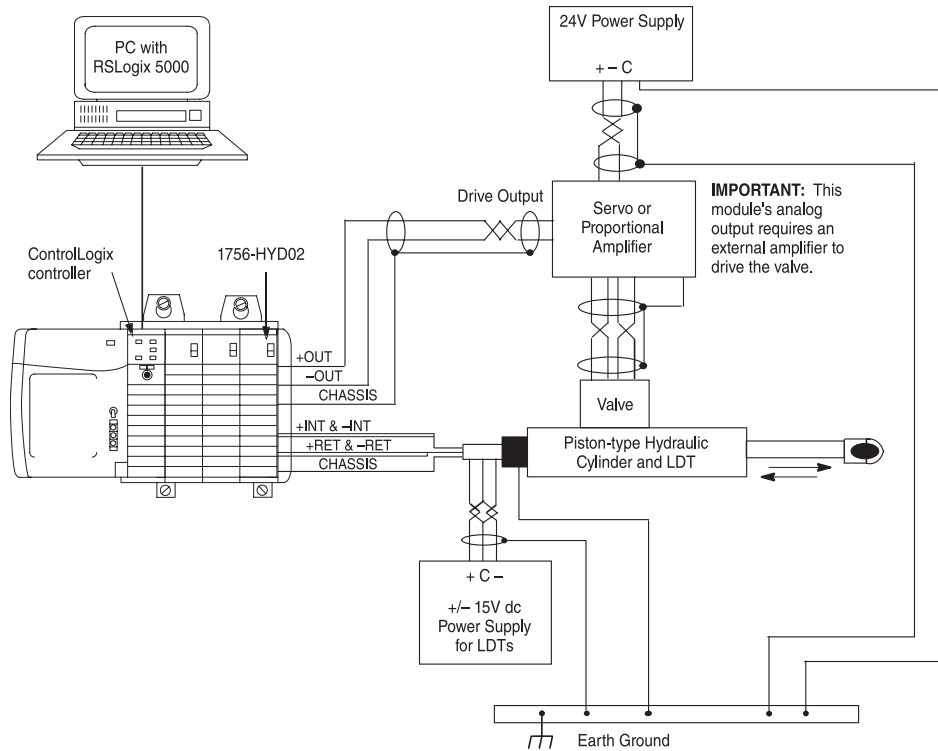

Step 3 - Select:

- *networks*
- *communication modules*
- *associated cable(s) and network equipment*
- *sufficient modules and cables if you are planning a redundant system*

Selecting Network Communications

Separate communication interface modules are available for different networks. Install multiple communication interface modules into the ControlLogix backplane to configure a gateway to bridge or route control and information data between the different networks.

Messages are sent directly from one communication interface module across the backplane to another. You can route a message through a maximum of 4 chassis (8 communication hops). You do not need a ControlLogix controller in the chassis.

NetLinx Open Network Architecture

NetLinx Open Network Architecture is the Rockwell Automation strategy of using open networking technology for seamless, top-floor to shop-floor integration. The networks in the NetLinx architecture – DeviceNet, ControlNet, and EtherNet/IP – speak a common language and share a universal set of communication services. NetLinx architecture, part of the Integrated Architecture, seamlessly integrates all the components in an automation system from a few devices on one network to multiple devices on multiple networks including access to the Internet – helping you to improve flexibility, reduce installation costs, and increase productivity.

- EtherNet/IP is an open industrial networking standard that supports implicit and explicit messaging and uses commercial, off-the-shelf Ethernet equipment and physical media.
- ControlNet allows intelligent, high-speed control devices to share the information required for supervisory control, work-cell coordination, operator interface, remote device configuration, programming, and troubleshooting.
- DeviceNet offers high-speed access to plant-floor data from a broad range of plant-floor devices and a significant reduction in wiring.

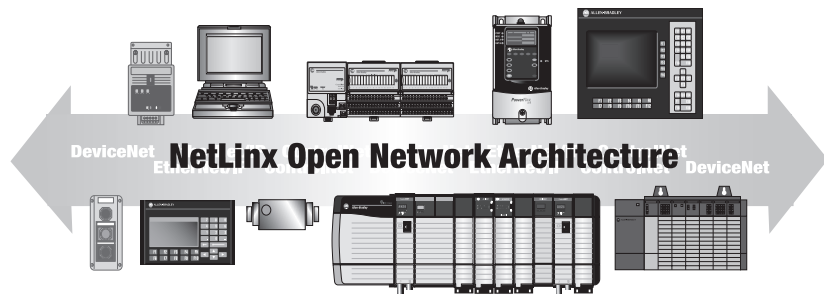

Selecting a network

You can configure your system for information exchange between a range of devices and computing platforms and operating systems.

If your application requires:	Use this network:	Select:
<ul style="list-style-type: none"> plant management (material handling) configuration, data collection, and control on a single, high-speed network time-critical applications with no established schedule data sent regularly Internet/Intranet connection 	EtherNet/IP network	1756-ENBT 1756-EWEB
<ul style="list-style-type: none"> high-speed transfer of time-critical data between controllers and I/O devices deterministic and repeatable data delivery media redundancy controller redundancy intrinsic safety redundant controller systems 	ControlNet network	1756-CNB, -CNBR
<ul style="list-style-type: none"> connections of low-level devices directly to plant floor controllers, without interfacing them through I/O modules data sent as needed more diagnostics for improved data collection and fault detection less wiring and reduced start-up time than a traditional, hard-wired system 	DeviceNet network	1756-DNB
<ul style="list-style-type: none"> plantwide and cell-level data sharing with program maintenance data sent regularly transfer of information between controllers 	Data Highway Plus	1756-DHRIO
<ul style="list-style-type: none"> connections between controllers and I/O adapters data sent regularly distributed control so that each controller has its own I/O and communicates with a supervisory controller 	Universal Remote I/O network	1756-DHRIO
<ul style="list-style-type: none"> Fieldbus transmitters and actuators closed-loop control process automation 	Fieldbus network	1788-CN2FF
<ul style="list-style-type: none"> modems supervisory control and data acquisition (SCADA) 	serial network	built-in serial port 1756-MVI, -MVID
<ul style="list-style-type: none"> connections to existing DH-485 networks 	DH-485 network	built-in serial port

For more specialized communication requirements, select:

If your application requires:	Use this:
SynchLink fiber optic communications to: <ul style="list-style-type: none"> controllers power distribution systems PowerFlex 700S 	1756-SYNCH 1756-DMxxx
AutoMax DCS network communications	56AMXN
remote access to controllers	9300-RADKIT

EtherNet/IP Network

Ethernet Industrial Protocol (EtherNet/IP) is an open industrial networking standard that supports both real-time I/O messaging and message exchange. It emerged due to the high demand for using the Ethernet network for control applications. EtherNet/IP uses off-the-shelf Ethernet communication chips and physical media. Because Ethernet technology has been used since the mid 1970s and is widely accepted throughout the world, Ethernet products serve a large community of vendors.

EtherNet/IP product capability

	Recipient								
	EtherNet/IP PLC-5 or SLC 5/05 processor	PLC-5 processor via 1785-ENET	Logix controller*	1756-ENBT module*	1794-AENT FLEX I/O adapter	1734-AENT POINT I/O adapter	PanelView EtherNet/IP terminal	RSLinx software	CompactLogix controller with 1761-NET-ENI interface
EtherNet/IP PLC-5 or SLC 5/05 processor	information	information	information	na	not supported	not supported	information	information	information
PLC-5 processor via 1785-ENET	information	information	information	na	not supported	not supported	information	information	information
Logix controller*	information	information	information I/O data interlocking	I/O data	I/O data	I/O data	information I/O data	information	information
PanelView EtherNet/IP terminal	information	information	information I/O data	na	na	na	na	na	information
RSLinx software	information	information	information	na	not supported	not supported	na	information	information
CompactLogix controller with 1761-NET-ENI interface†	information	information	information	na	not supported	not supported	information	information	information

* For EtherNet/IP control:

- a ControlLogix controller requires a 1756-ENBT or 1756-ENET series B module
- a FlexLogix controller requires a 1788-ENBT card
- a CompactLogix controller must be a 1769-L32E or 1769-L35E controller
- the PC for a SoftLogix5800 controller requires appropriate hardware for Ethernet communications

†To be an originator, the 1761-NET-ENI interface must connect to the other device through that device's RS-232 port.



Ethernet interfaces

Select the appropriate Ethernet interface:

If your application does this:	Select this interface:	Description:
<ul style="list-style-type: none"> controls I/O modules requires an adapter for disibuted I/O on EtherNet/IP links communicates with other EtherNet/IP devices (messages) bridges EtherNet/IP links to route messages to devices on other networks 	1756-ENBT	<p>The EtherNet/IP communication module:</p> <ul style="list-style-type: none"> control I/O over an EtherNet/IP network acts as an adapter for disitributed I/O on remote EtherNet/IP links bridge EtherNet/IP links to route messages to devices on other networks
<ul style="list-style-type: none"> requires remote access via Internet browser to tags in a local ControlLogix controller communicates with other EtherNet/IP devices (messages) bridges EtherNet/IP links to route messages to devices on other networks 	1756-EWEB	<p>The enhanced web server module provides Internet browser access to ControlLogix controllers so you can monitor and modify data remotely via XML web pages. The web server module supports:</p> <ul style="list-style-type: none"> data access (read and write) to ControlLogix controllers bridging and routing of messages custom web pages email capability

Cat. No.	Communication Rate	ConnectionsConnections	Power Dissipation, Max.	Backplane Current (mA) at 5V	Backplane Current (mA) at 24V
1756-ENBT	10/100 Mbps	Each module supports a maximum of:	3.65 W	700 mA	3 mA
1756-EWEB		<ul style="list-style-type: none"> 64 TCP/IP connections 128 Logix connections (I/O and information) 5000 messages/second 	3.65 W	700 mA	3 mA

Certifications: UL, CSA (Class I, Division 2, Group A, B, C, D), CE, FM, C-Tick

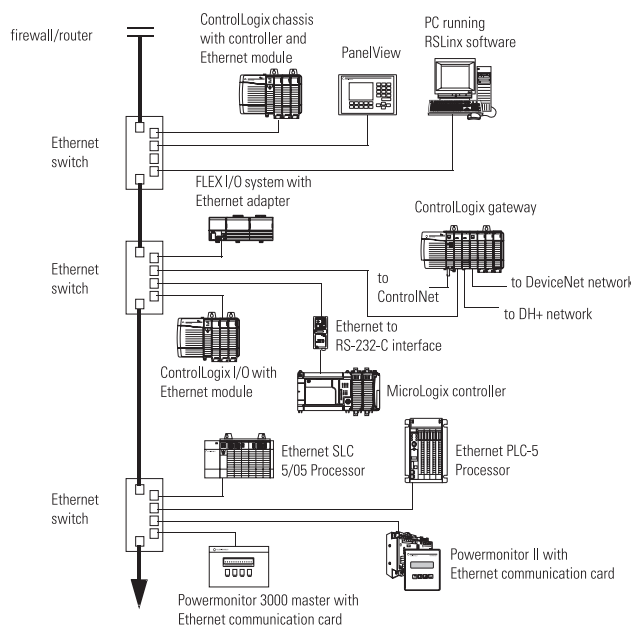

ControlNet Network



The ControlNet network is an open, state-of-the-art control network that meets the demands of real-time, high-throughput applications. The ControlNet network uses the proven Common Industrial Protocol (CIP) to combine the functionality of an I/O network and a peer-to-peer network providing high-speed performance for both functions.

The ControlNet network gives you deterministic, repeatable transfers of all mission-critical control data in addition to supporting transfers of non-time-critical data. I/O updates and controller-to-controller interlocking always take precedence over program uploads and downloads and messaging.

Cat. No.	Communication Rate	Connections	Cable	Power Dissipation, Max.	Backplane Current (mA) at 5V	Backplane Current (mA) at 24V
1756-CNB	5 Mbps	64 connections per module	RG-6 coaxial cable 1786-RG6 (shield high flex cable) 1786-RG6F (quad shield high flex coax cable) 1786-XT termination resistor	5.14 W	970 mA	2 mA
1756-CNBR			Choose taps: • 1786-TPR (T-tap right angle) • 1786-TPS (T-tap straight) • 1786-TPYR (Y-tap right angle) • 1786-TPYS (Y-tap straight)	5.14 W	1000 mA	2 mA

Certifications: UL, CSA (Class I, Division 2, Group A, B, C, D), CE, FM, C-Tick

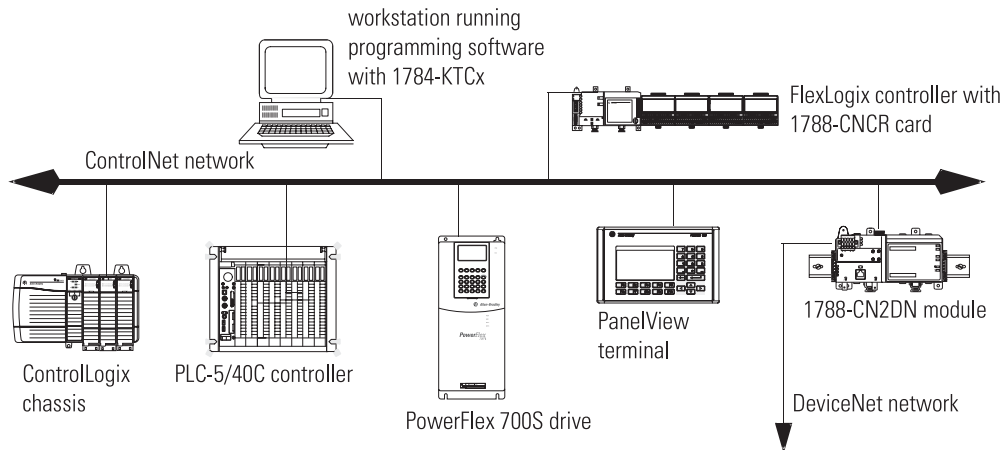

Redundant controller systems via ControlNet

You can build a redundant controller system around a ControlNet network. In each redundant controller chassis, you can have:

- one or two 1756-L55 controllers or one 1756-L6x controller in each redundant chassis
- at least one, but no more than five, 1756-CNB(R) series D, version 5.23 (or greater) communication modules in each redundant chassis
- one 1757-SRM module in each redundant chassis
- the redundant chassis can contain a 1756-ENBT communication module, but no other I/O or communication modules can be in the redundant chassis

All I/O must be remote from the redundant controllers. ControlLogix redundancy works with remote 1756 I/O, FLEX I/O, drives, operator interfaces, or any other devices that can communicate with a ControlLogix controller over a ControlNet link. To connect to other networks, bridge through another ControlLogix chassis (not one of the redundant controller chassis)

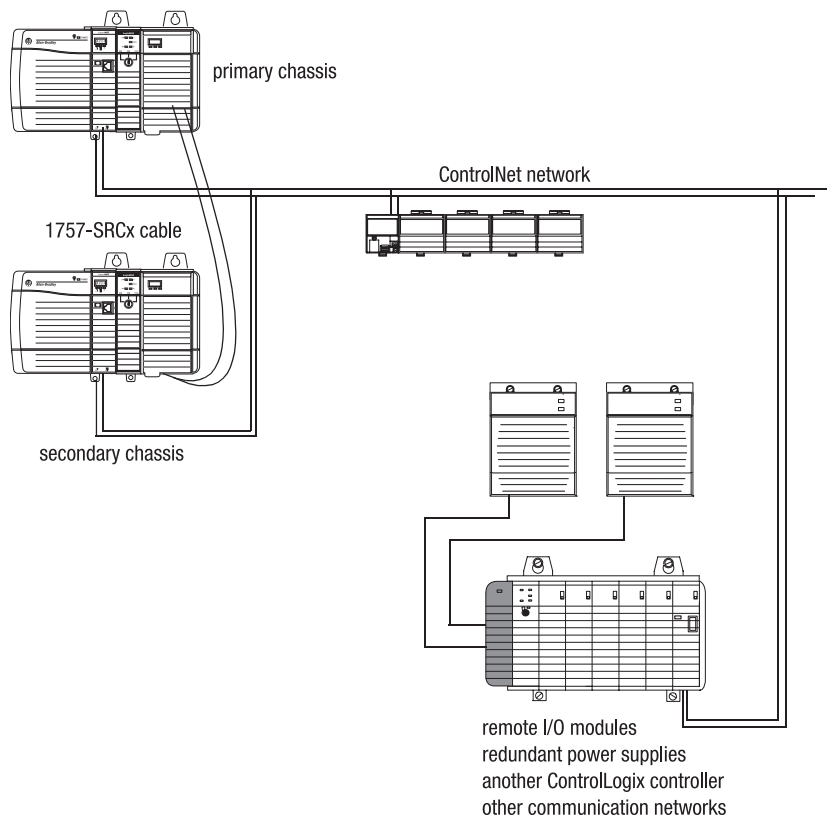

The secondary controller is synchronized with the primary controller to provide a bumpless switchover for any outputs controlled by logic in the highest priority task. Switchover occurs within 100msec.

Make sure that your ControlNet network contains at least two nodes in addition to the redundant chassis pair. And additional node can be:

- a second 1756-CNBR module in the same remote chassis or in a different remote chassis
- any ControlNet device
- a workstation running RSLinx software

1757-SRM redundancy module

The 1757-SRM redundancy module provides high-speed data transfers between the primary and secondary chassis. You need one 1757-SRM module per chassis. The module supports as many as five 1756-CNB modules per chassis.

Cat. No.	Cable	Voltage/Current	Power Dissipation, Max.	Current Capacity (Amps) at 3.3V	Backplane Current (mA) at 5V	Backplane Current (mA) at 24V
1757-SRM	Choose: <ul style="list-style-type: none"> • 1757-SRC1 (1m) • 1757-SRC3 (3m) • 1757-SRC10 (10m) • 1757-SRC50 (50m) • 1757-SRC100 (100m) 	30V ac/dc maximum 100 mA maximum		0.75 A	1.0 A	0.09 A

Certifications: UL, CSA (Class I, Division 2, Group A, B, C, D), CE, FM, C-Tick

Connecting to other devices via ControlNet

The RSLogix 5000 Enterprise Series software supports a generic ControlNet module that allows connections to ControlNet nodes for which there is no specific support currently available in the programming software. A module configured as a generic ControlNet module communicates with the controller in the form of input, output, status, and configuration tags. These tags and their characteristics vary depending on the type of module.

For example, use the generic module configuration to set up communications between a ControlLogix controller and a 1203-CN1 ControlNet communication module. Then use the CIP generic MSG instruction type to send and receive messages from the 1203-CN1 module.

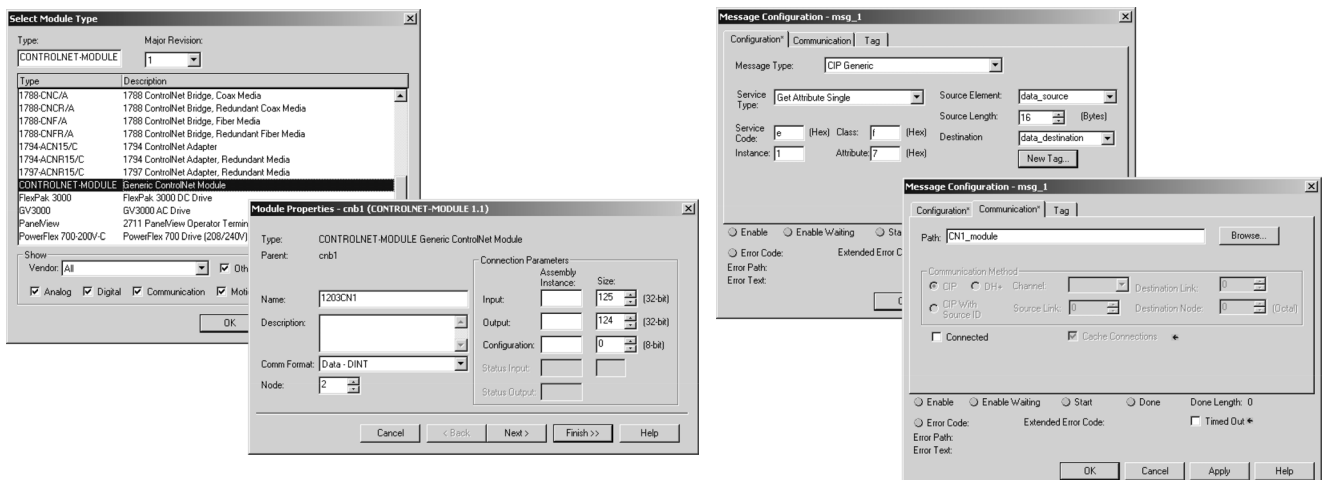

DeviceNet Network



The DeviceNet network is an open low-level network that provides connections between simple industrial devices (such as sensors and actuators) and higher-level devices (such as PLC controllers and computers). The DeviceNet network uses the proven Common Industrial Protocol (CIP) to provide the control, configure, and data collection capabilities for industrial devices. The DeviceNet network is a flexible network that works with devices from multiple vendors.

Cat. No.	Communication Rate	Connections	Cable	Power Dissipation, Max.	Backplane Current (mA) at 5V	Backplane Current (mA) at 24V
1756-DNB	<ul style="list-style-type: none"> • 125 Kbps • 250 Kbps • 500 Kbps 	2 connections to dedicated ControlLogix controller	Choose: <ul style="list-style-type: none"> • KwikLink™ flat media • thick trunk round media • thin trunk round media 	5.3 W	600 mA	3 mA

Certifications: UL, CSA (Class 1, Division 2, Group A, B, C, D), CE, FM, C-Tick

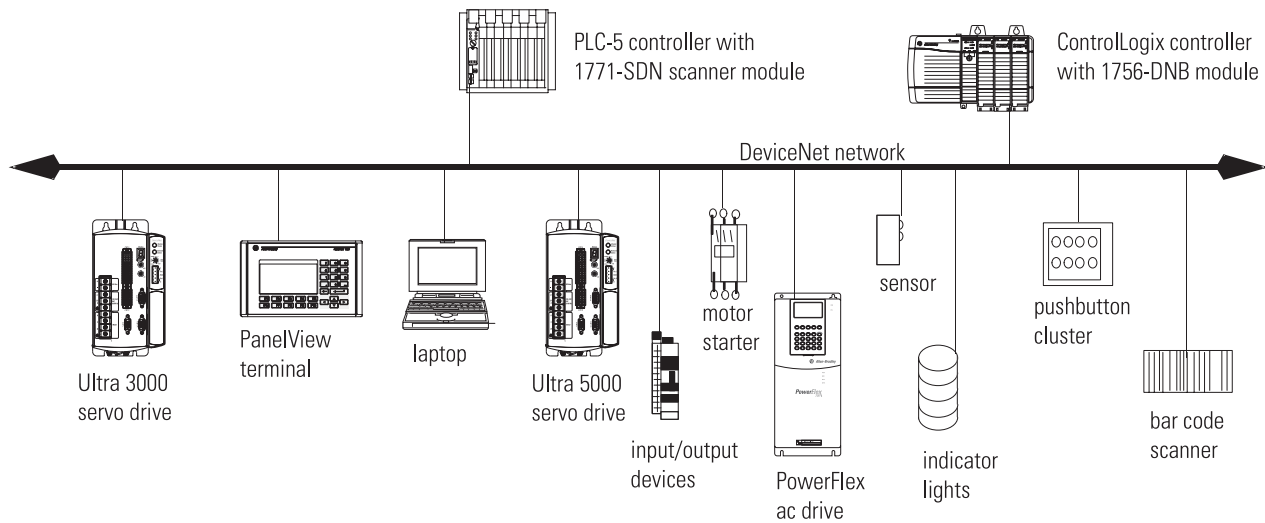

DH+ and Universal Remote I/O Networks



The DH+ and remote I/O module supports messaging between devices on DH+ networks. The remote I/O functionality enables the module to act as a scanner for transferring discrete and block-transfer data to and from remote I/O devices.

Cat. No.	Communication Rate	Connections	Cable	Power Dissipation, Max.	Backplane Current (mA) at 5V	Backplane Current (mA) at 24V
1756-DHRIO	<ul style="list-style-type: none"> • 57.6 Kbps • 115.2 Kbps • 230.4 Kbps 	32 connections per DH+ channel 32 logical rack connections per remote I/O channel 16 block-transfer connections per remote I/O channel	1770-CD Belden 9463 150Ω and 82Ω termination resistors ship with the module	4.5 W	850 mA	2 mA

Certifications: UL, CSA (Class 1, Division 2, Group A, B, C, D), CE, FM, C-Tick

DH+ example configuration

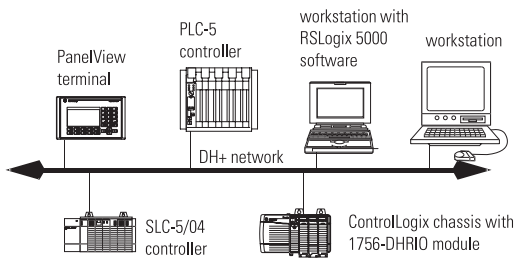

Universal remote I/O example configuration

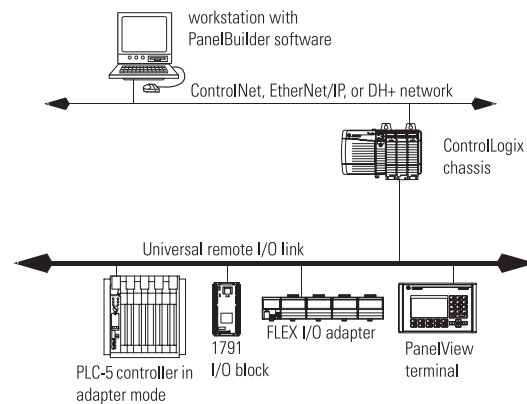

Foundation Fieldbus Network



Foundation Fieldbus™ is a communications network created by the Fieldbus Foundation. It is a protocol designed for robust, distributed control of process control applications. Devices connected by a Foundation Fieldbus network can be used for sophisticated, highly-distributed process control.

Select the appropriate Foundation Fieldbus interface:

If your application bridges to Foundation Fieldbus from:	Select this interface:	Description:
ControlNet	1788-CN2FF	The 1788-CN2FF linking device adds Foundation Fieldbus support to your ControlLogix system. You can have one linking device per ControlNet tap. The device connects to two, independent Fieldbus H1 networks.
EtherNet/IP	1757-FFLD	The 1756-FFLD linking device bridges from Ethernet to H1. It accepts either HSE or EtherNet/IP messages and converts them to the H1 protocol. By supporting H1, HSE and EtherNet/IP protocols, the 1756-FFLD is capable of providing bridging capability of Rockwell Automation products and Foundation Fieldbus products on Ethernet to products on H1 links.

Cat. No.	Communication Rate	Connections	Backplane Current (mA) at 24V
1788-CN2FF	2 ms over ControlNet 31.25 Kbps over Fieldbus	two H1 networks	270 mA
1757-FFLD2	10/100 Mbps over EtherNet/IP	two H1 networks	300 mA
1757-FFLD4	31.25 Kbps over Fieldbus	four H1 networks	300 mA

Certifications: UL, CSA (Class 1, Division 2, Group A, B, C, D), CE, FM, C-Tick

1788-CN2FF example configuration

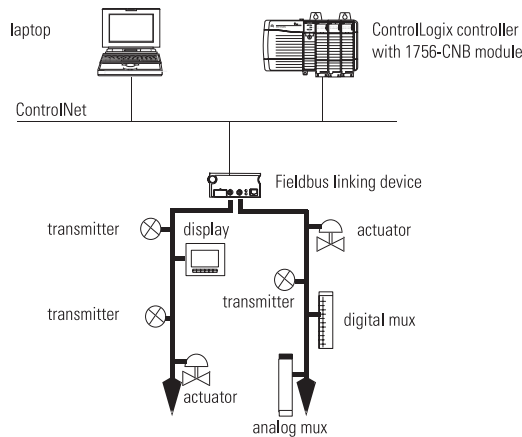

1757-FFLD example configuration

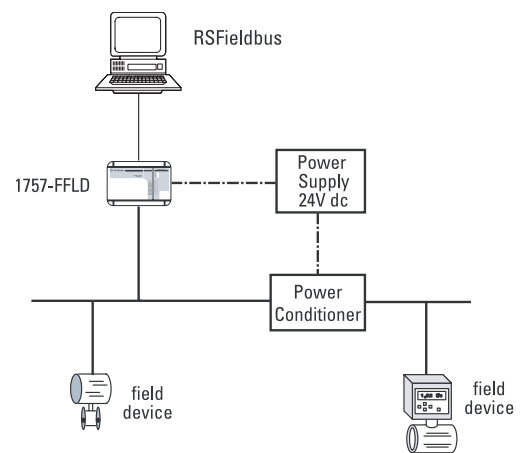

Serial Network

The serial port is compatible with RS-232 serial communication. The serial port supports the DF1 protocol to communicate with other devices on the serial link. You can select:

Use this DF1 mode:	For:
point to point	communication between a controller and other DF1-compatible devices using DF1 full-duplex protocol
DF1 master	control of polling and message transmission between the master and each slave using DF1 half-duplex polled protocol
DF1 slave	using the controller as a slave station in a master/slave serial network using DF1 half-duplex protocol
user mode (ASCII)	communication between a controller and an ASCII device, such as a bar code reader

Use a 1756-CP3 cable to connect to the serial port.

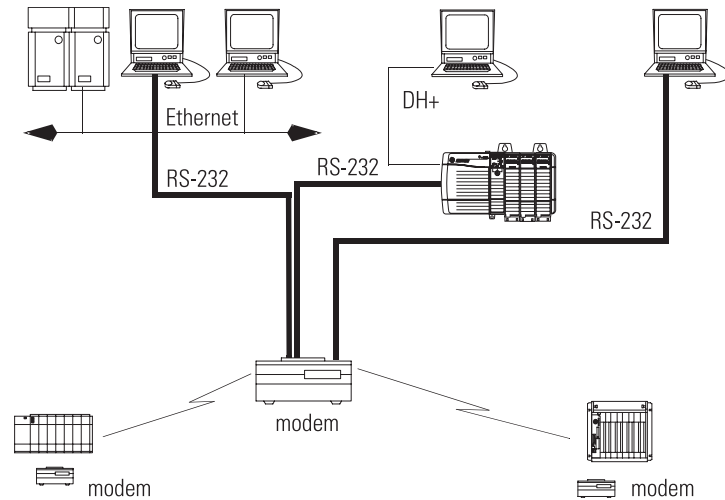

Over the serial port, the ControlLogix controller supports 12 message buffers. At most, you can have 4 simultaneous connected messages and 8 simultaneous unconnected messages. Or if all the messages are unconnected, you can have 12 simultaneous messages. If a message is greater than 250 bytes, it is divided across enough buffers to carry the message, which reduces the number of buffers remaining for other simultaneous messages.

1756-MVI, -MVID multi-vendor interface module

The multi-vendor interface module provides additional access to serial devices. The module is programmable to accommodate devices with unique serial protocols.

Cat. No.	Communication Rate	Connections	Cable	Power Dissipation, Max.	Backplane Current (mA) at 5V	Backplane Current (mA) at 24V
1756-MVI	Configurable, depending on serial protocol	PRT1: RS-232 PRT2: RS-232, RS-422, RS-485 PRT3: RS-232, RS-422, RS-485	3 serial adapter cables ship with the module. At one end of the cables is a locking-type RJ-45 connector to the module; at the other end is a DB-9 male connector.	4 W	800 mA	3 mA
1756-MVID (1756-MVI module and API software)						

Certifications: UL, CSA (Class I, Division 2, Group A, B, C, D), CE, FM, C-Tick

Modbus support

To use Logix5000 controllers on Modbus, you connect through the serial port and execute a specific ladder logic routine. The ladder logic routine is available on the CD for RSLogix 5000 Enterprise programming software. For more information, see *Using Logix5000 Controllers as Masters or Slaves on Modbus Application Solution*, publication CIG-AP129A-EN-P.

DH-485 Network

On the DH-485 network, the controller can send and receive messages to and from other controllers on the network. The DH-485 connection does support remote programming and monitoring via RSLogix 5000 software. However, excess traffic over a DH-485 connection can adversely affect overall performance and can lead to timeouts and loss in RSLogix 5000 configuration performance.

Important: Only use Logix controllers on DH-485 networks when you want to add controllers to an existing DH-485 network. For new applications with Logix controllers, networks in the NetLinx architecture are the recommended networks.

You need a 1761-NET-AIC+ converter for each controller you want to put on the DH-485 network. You can have two controllers per one 1761-NET-AIC+ converter, but you need a different cable for each controller. Connect one controller to port 1 (9-pin connector) and one controller to port 2 (mini-DIN connector).

If you connect to this port:	Use this cable:
port 1 DB-9 RS-232, DTE connection	1747-CP3 or 1761-CBL-AC00
port 2 mini-DIN 8 RS-232 connection	1761-CBL-AP00 or 1761-CBL-PM02

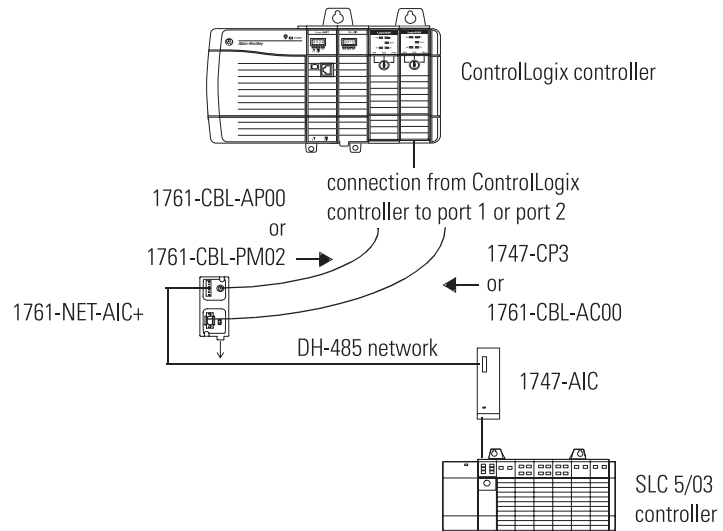

SynchLink

SynchLink provides time synchronization and data broadcasting capabilities for distributed motion and coordinated drive control.

1756-SYNCH SynchLink module

The 1756-SYNCH SynchLink module connects a ControlLogix chassis to a SynchLink fiber optic communications link. The module:

- coordinates CST time across multiple ControlLogix chassis
- moves limited amount of data from one chassis to another at a high speed
- lets one controller consume motion axes data from a controller in another chassis

Cat. No.	Communication Rate	Cable	Power Dissipation, Max.	Backplane Current (mA) at 5V	Backplane Current (mA) at 24V
1756-SYNCH	operating wavelength: 650 nm (red) data rate: 5 Mbps baud rate: 5 Mbps	Order 1403-CF xxx cable or from Lucent Technologies, Specialty Fiber Technologies division* maximum length 200/230 micron Hard Clad Silica (HCS) Versalink V-System300 m minimum length 1 m	6.19 W	1200 mA	2.5 mA

Certifications: UL, CSA (Class I, Division 2, Group A, B, C, D), CE
*The xxx determines the length. Select 001, 003, 005, 010, 020, 050, 100, or 250 meters.

Star configuration

Requires:

1751-SLBA base block
1751-SL4SP 4-port splitter block

Supports:

2 layers of hubs
16 end nodes per hub
257 nodes (including master node) per star network

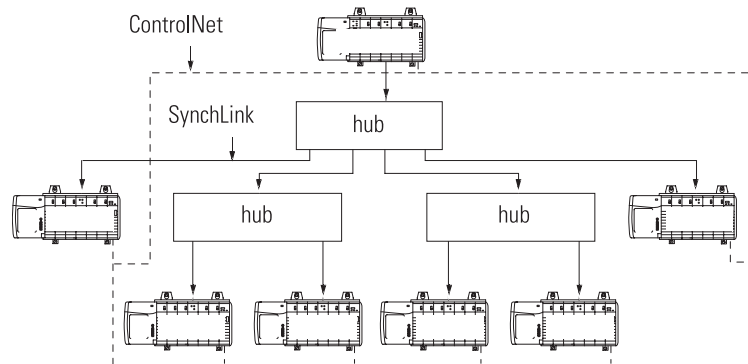

Daisy chain configuration

Optional:

1751-SLBP bypass switch block

Supports:

10 nodes (including master and end nodes) per daisy chain network

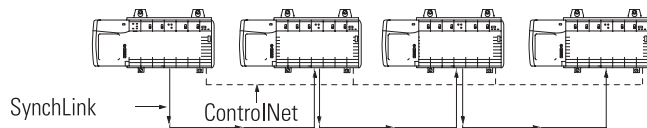

Ring configuration

Optional:

1751-SLBP bypass switch block

Supports:

10 nodes (including master and end nodes) per ring network

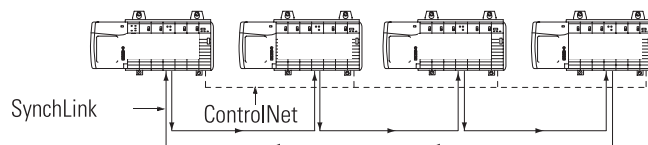

1756-DMxxx module

The 1756-DM drive module lets you update and retrofit Reliance distributed power system (DPS) installations to ControlLogix-based systems. Each drive module interfaces with an individual Power Module Interface (PMI) chassis. You can also use the 1756-DM to modernize existing power bridges from analog to digital control.

Cat. No.*	Communicates with
1756-DMD30	SD3000 dc drive
1756-DMF30	SF3000 Regen field control
1756-DMA30	SA3000 ac drive
1756-DMA31	SA3100 ac drive

*The 1756-DM modules are only available through Drive Systems.

Cat. No.	Operating Wavelength	Data Rate	Cable	Maximum Node Count	Backplane Current (mA) at 5V	Backplane Current (mA) at 24V
1756-DMxxx SynchLink values	650 nM (red)	5 Mbps	200/230 micron Hard Clad Silica (HCS); VersaLink V-system Order 1403-CF xxx power monitoring cable or from Lucent Technologies, Specialty Fiber Technologies division* maximum length 300m minimum length 1m	10 daisy chain configuration 256 star configuration with multiplexing blocks	1.35 A	3.0 mA
1756-DMxxx Drive communications values	820 nM (infrared)	10 Mbps	62.5/125 micron glass; one pair SC Style and one pair ST Style Order 1756-DMCF xxx drive communications fiber optic cable or breakout cable from Belden 225362 or Mohawk M92021† maximum length 300m minimum length 1m	1 PMI chassis		

Certifications: UL, CSA (Class 1, Division 2, Group A, B, C, D), CE

*The xxx determines the length. Select 001, 003, 005, 010, 020, 050, 100, or 250 meters.

†The xxx determines the length. Select 001, 003, 010, or 030 meters.

Existing power systems

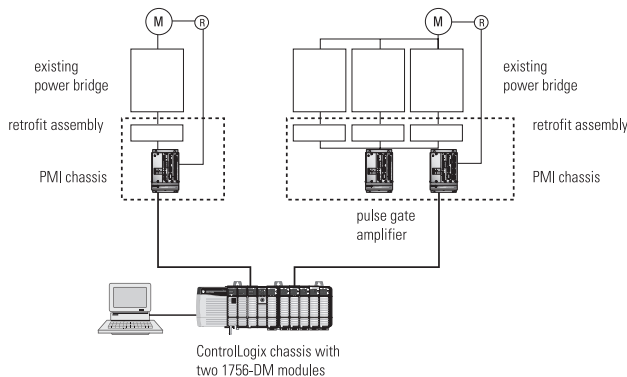

Distributed power systems

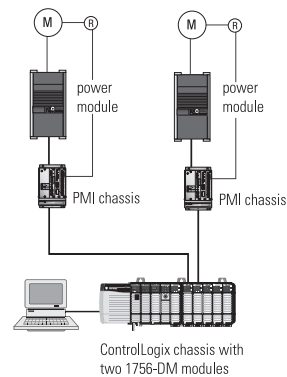

56AMXN AutoMax Network and RE Remote I/O



The 56AMXN module connects a ControlLogix system to an AutoMax DCS network or to an AutoMax Remote I/O network. The traditional Reliance Electric Systems solution is based on an AutoMax controller and architecture. DCSNet is the main communications, data, and control network or “backbone”. RE RIO is the Remote I/O architecture to network devices such as I/O and MMI or HMI operator stations.

You configure the 56AMXN as a generic module. The module supports scheduled data up to 250 words of input, 248 words of output, and 250 words of status data. The module supports RPIs from .2 to 750ms.

As a:	The 56AMXN module:
DCSNet master	<ul style="list-style-type: none"> Scans up to 55 drops with 32 words in and 32 words out per drop Transmits 8 words of global broadcast data every 2.8ms Maintains standard drop 0 diagnostic counters
DCSNet slave	<ul style="list-style-type: none"> Acts as any drop number from 1 to 55, with drop depth from 1 to 55 (“active drops”) Monitors input and output data on other drops on the network (“monitored drops”)
RE remote I/O master	<ul style="list-style-type: none"> Scans up to 7 drops, with up to 248 words of output data and 250 words of input data Maintains standard diagnostic counters

Cat. No.	Communication Networks and Supported Modes	Cable	Power Dissipation, Max.	Backplane Current (mA) at 5V	Backplane Current (mA) at 24V
56AMXN	DCS network: master or slave RE remote I/O network: master	Drop cable (612574-36R, 3ft long with 9-pin D-shell connectors) and passive tap (M/N 57C380, BNC connectors) connects the module to the network cable. For DCS, the network cable can be RG-59/U or RG-11/U. For remote I/O, the cable must be RG-59/U.	5.0 W	650 mA	75 mA

Certifications: UL, CSA (Class I, Division 2, Group A, B, C, D), CE

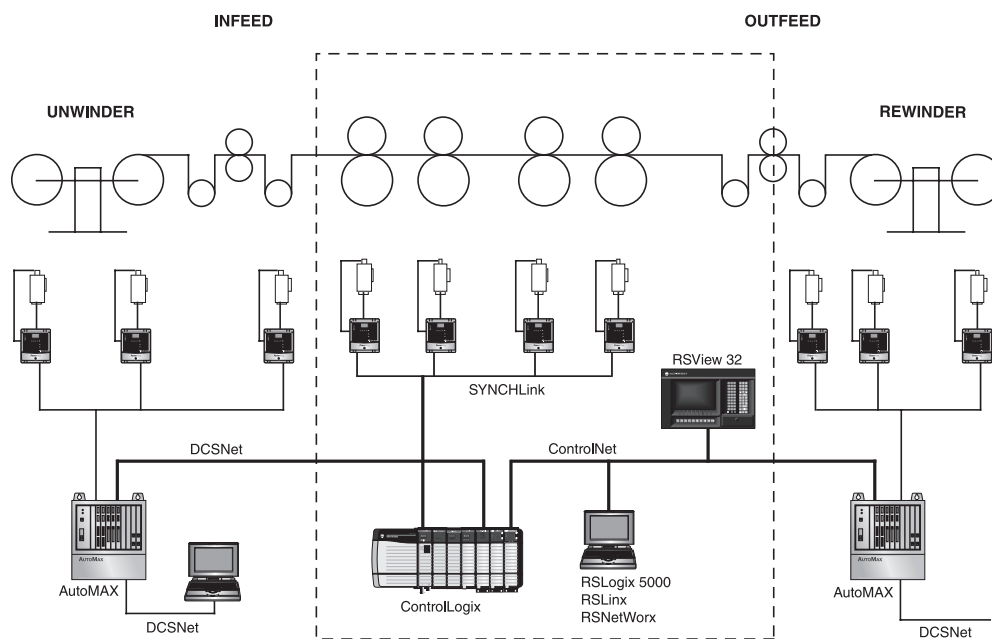

Accessing the Controller Remotely



Remote access dial-in kits let you connect via modem to a remote site's network and controller. Once connected, you can monitor the process, collect data, and make program changes remotely. Each remote access dial-in kit includes:

- pre-configured modem
- communication module
- DIN rail mounting hardware
- associated cables

Each kit also includes a CD-ROM-based installation guide and tutorial that takes you step-by-step through establishing a remote dial-in connection.

Cat. No.	Communication	Supported Controllers	Power Requirements
9300-RADES	56K modem connection to devices on Ethernet	<ul style="list-style-type: none"> • ControlLogix, CompactLogix, FlexLogix controllers • MicroLogix controllers 	8-48V dc 200 mA at 24V dc
9300-RADKIT	56K modem connection to devices on DH+ or DH-485	<ul style="list-style-type: none"> • Enhanced PLC-5 processors • SLC 5/03, 5/04, 5/05 processors • 1203-SSS 	8-48V dc 100 mA at 12V dc

The modem supports remote configuration, so you can modify the remote network modem's command settings through a dial-up connection. This helps you recover modem communication if a change occurs in the controller's channel configuration.

The remote access modem also has call-back security which is authenticated with a password.

Step 4 - Select:

- a controller with sufficient memory
- memory board for each 1756-L55 controller
- 1756-BATM for larger memory size 1756-L55 controllers and all 1756-L6x controllers
- replacement batteries



Selecting Controllers

The ControlLogix controller provides a scalable controller solution that is capable of addressing a large amount of I/O points (128,000 digital maximum / 4000 analog maximum).

The ControlLogix controller can be placed into any slot of a ControlLogix I/O chassis and multiple controllers can be installed in the same chassis. Multiple controllers in the same chassis communicate with each other over the backplane (just as controllers can communicate over networks) but operate independently.

ControlLogix controllers can monitor and control I/O across the ControlLogix backplane, as well as over I/O links. ControlLogix controllers can communicate with computers or other processors across RS-232-C (DF1/DH-485 protocol), DeviceNet, DH+, ControlNet, and EtherNet/IP networks. To provide communication for a ControlLogix controller, install the appropriate communication interface module into the chassis.

The multi-tasking operating system supports 32 configurable tasks that can be prioritized. One task can be continuous. The others must be periodic or event tasks. Each task can have as many as 32 programs, each with its own local data and logic, allowing virtual machines to operate independently within the same controller.

Specification	Description
Battery	1756-BA1 (94194801) - comes with the controller or 1756-BATM (contains a 1756-BATA battery assembly) *
Programming Cable	1756-CP3 or 1747-CP3 serial cable

Certifications: UL, CSA (Class 1, Division 2, Group A, B, C, D), CE, FM (1756-L6x controllers only), C-Tick, EEx ATEX
*The battery module is highly recommended for all controllers.

ControlLogix Controllers

Cat. No.	Memory			Power Dissipation, Max.	Thermal Dissipation, Max.	Backplane Current (mA) at 5V	Backplane Current (mA) at 24V
	Data and Logic*	I/O†	Nonvolatile Memory				
1756-L55M12	750 K bytes	208 Kbytes	no	5.6 W	19.1 BTU/hr	1.23 A	0.014 A
1756-L55M13	1.5 Mbytes	208 Kbytes	no	5.6 W	19.1 BTU/hr	1.23 A	0.014 A
1756-L55M14	3.5 Mbytes	208 Kbytes	no	5.7 W	19.4 BTU/hr	1.25 A	0.014 A
1756-L55M16	7.5 Mbytes ≤ 3.5 Mbytes of data	208 Kbytes	no	6.3 W	21.5 BTU/hr	1.48 A	0.014 A
1756-L55M22	750 K bytes	208 Kbytes	yes	5.6 W	19.1 BTU/hr	1.23 A	0.014 A
1756-L55M23	1.5 Mbytes	208 Kbytes	yes	5.6 W	19.1 BTU/hr	1.23 A	0.014 A
1756-L55M24	3.5 Mbytes	208 Kbytes	yes	5.7 W	19.4 BTU/hr	1.25 A	0.014 A
1756-L61	2 Mbytes	478 Kbytes	CompactFlash card‡	3.5 W	11.9 BTU/hr	1.20 A	0.014 A
1756-L62	4 Mbytes	478 Kbytes	CompactFlash card‡	3.5 W	11.9 BTU/hr	1.20 A	0.014 A
1756-L63	8 Mbytes	478 Kbytes	CompactFlash card‡	3.5 W	11.9 BTU/hr	1.20 A	0.014 A
1756-L60M03SE§	750 Kbytes	478 Kbytes	CompactFlash card‡	8.5 W	11.9 BTU/hr	1.96 A	0.0165 A

*Data and logic memory stores: tags other than I/O, produced, or consumed tags; logic routines; and communication with OPC/DDE tags that use RSLinx software (also uses I/O memory).

†I/O memory stores: I/O tags, produced tags, consumed tags, communication via MSG instructions, communication with workstations, and communication with OPC/DDE tags that use RSLinx software (also uses data and logic memory).

‡The CompactFlash card is available separately as 1784-CF64.

§The 1756-L60M03SE is a 1756-L60 ControlLogix controller with an embedded 1756-M03SE SERCOS interface. This is a 2-slot module.

The 1756-L6x controller executes ladder scans almost twice as fast as the 1756-L55 controllers and executes function block, REAL data type math, and motion instructions 4-5 times faster than the 1756-L55 controllers.

The 1756-L60M03SE controller combines a 1756-L6x controller and a SERCOS motion module in a two-slot module. This controller is ideal for small motion systems and can control 3 SERCOS axes with the included interface. This controller can control as many as 6 axes if you add an additional motion module.

Selecting a controller for a redundant controller system

If you are designing a redundant controller system, consider:

- Redundant controller systems support one or two 1756-L55 controllers or one 1756-L6x controller in each redundant chassis.
- Data is buffered in the secondary controller, so twice as much data memory space is required in the controller.
- The redundant controllers must be on a ControlNet network.

Determining Memory Requirements

The following equations provide an estimate of the memory needed for a controller. These numbers are rough estimates.

Controller tasks	_____ * 4000	=	_____ bytes (minimum 1 task)
Digital I/O points	_____ * 400	=	_____ bytes
Analog I/O points	_____ * 2600	=	_____ bytes
Communication modules*	_____ * 2000	=	_____ bytes
Motion axes	_____ * 8000	=	_____ bytes

*When estimating memory use by communication modules, count all the communication modules in the system, not just those in the local chassis. This includes device connection modules, adapter modules, and ports on PanelView terminals.

Controller memory boards

The 1756-L55 controllers do not operate stand-alone. Choose one of these memory boards to come already assembled with the controller. You can also order additional memory boards either for spare parts or to upgrade existing 1756-L55 controllers.

The 1756-L6x controllers have a fixed RAM size and do not use a memory board. Use a CompactFlash card for nonvolatile storage. You must remove the controller from the chassis to access the CompactFlash card.

Catalog Number:	Supported Controller:	Battery-Backed Static RAM:	Nonvolatile RAM:
1756-M12*	1756-L55	750 Kbytes	none
1756-M13	1756-L55	1.5 Mbytes	none
1756-M14	1756-L55	3.5 Mbytes	none
1756-M16	1756-L55	7.5 Mbytes 3.5 Mbytes for tag data	none
1756-M22*	1756-L55	750 Kbytes	750 Kbytes
1756-M23†	1756-L55	1.5 Mbytes	1.5 Mbytes
1756-M24†	1756-L55	3.5 Mbytes	3.5 Mbytes
1784-CF64	1756-L6x‡	none	same as the battery-backed static RAM limit for the controller

*The 1756-L55 controller must have firmware revision 10 or higher.

†The 1756-L55 controller must have firmware revision 8 or higher.

‡You can use CompactFlash with the 1756-L61, -L62, -L63, and -L60M03SE controllers. The 1756-L61, -L62 controllers require firmware revision 12 or greater. The 1756-L63 controller requires firmware revision 11 or higher. The 1756-L60M03SE controller requires firmware revision 13 or higher.

Non-volatile memory

The nonvolatile memory (flash) lets you permanently store a user program and tag data on a controller. You can:

- manually trigger the controller to save to or load from nonvolatile memory
- configure the controller to load from nonvolatile memory on power up

The 1756-L55M2x controllers have fixed internal nonvolatile memory.

The 1756-L6x controllers support a removable CompactFlash card for nonvolatile memory. You install the 1784-CF64 card in a socket in the controller. You must remove the controller from the chassis to install CompactFlash. The CompactFlash card stores the user program, tag data, and controller firmware. This lets you upgrade firmware on a 1756-L6x controller without using RSLogix 5000 or ControlFlash software.

Determining Battery Requirements

Each controller ships with a 1756-BA1 battery. An externally mounted, higher-capacity battery module is also available (1756-BATM).

Cat. No.	Description	Estimated Worst Case Battery Life @ 25C
1756-BA1	Lithium battery (0.59g) installed in each ControlLogix controller. Order only if you need a replacement.	<ul style="list-style-type: none"> with 1756-L55M12: 63 days with 1756-L55M13: 63 days with 1756-L55M14: 30 days with 1756-L55M16: 13 days with 1756-L6x: 21 days
1756-BATM	Externally mounted battery assembly. Provides longer battery life than the 1756-BA1. Contains: <ul style="list-style-type: none"> one 1756-BATA assembly 1m cable to connect housing to controller Highly recommended for all controllers (see chart below).	<ul style="list-style-type: none"> with 1756-L55M12: 299 days with 1756-L55M13: 299 days with 1756-L55M14: 213 days with 1756-L55M16: 133 days with 1756-L6x: 146 days
1756-BATA	Lithium battery assembly (maximum of 5g lithium per each D cell; assembly contains 2 D cells) included with the 1756-BATM. Order only if you need a replacement.	

The 1756-BATM battery module is recommended for use with all 1756-L55 and 1756-L6x controllers.

If You Order This Controller	1756-BATM	1756-BA1	1756-BA1
1756-L55M12	recommended	for a replacement	for a replacement
1756-L55M13	recommended	for a replacement	for a replacement
1756-L55M14	highly recommended	for a replacement	for a replacement
1756-L55M16	highly recommended	for a replacement	not recommended for long-term use
1756-L55M22*	recommended	for a replacement	for a replacement
1756-L55M23*	recommended	for a replacement	for a replacement
1756-L55M24*	highly recommended	for a replacement	not recommended for long-term use
1756-L61†	highly recommended	for a replacement	not recommended for long-term use
1756-L62†	highly recommended	for a replacement	not recommended for long-term use
1756-L63†	highly recommended	for a replacement	not recommended for long-term use

*These controllers have nonvolatile memory and can be used without a battery.

†The 1756-L6x controllers have nonvolatile memory if you install a 1784-CF64 CompactFlash card. With nonvolatile memory, the controller can be used without a battery. If you do not use a battery, current tag data will be at the state they were when the nonvolatile memory was saved.

Controlling Devices

The ControlLogix controller can control these devices:

I/O Modules	EtherNet/IP	ControlNet	DeviceNet	Universal Remote I/O
1756 ControlLogix I/O	yes	yes	no	no
1794 FLEX I/O	yes	yes	yes	yes
1793 FLEX Integra I/O	yes*	yes*	yes	yes
1797 FLEX Ex I/O	no	yes	no	no
1734 POINT I/O	yes	yes	yes	no
1734D POINT Block I/O	no	no	yes	no
1769 Compact I/O	no	no	yes	no
1790 Compact LDX I/O	no	no	yes	no
1791 Block I/O	no	no	no	yes
1791D CompactBlock I/O	no	no	yes	no
1792 ArmorBlock I/O	no	no	yes	no
1798 FlexArmor I/O	no	no	yes	no
1799 Embedded I/O	no	no	yes	no
1747 SLC I/O		no	no	yes
1771 I/O	no	yes†	no	yes

*Requires RSLogix 5000 programming software version 11 or greater. Use the generic FLEX profile.

†Use a 1771-ACN15, -ACNR15 adapter module. Version 10 and later of RSLogix 5000 Enterprise Series software supports 1771 digital, analog, and specialty I/O modules. Previous versions of the software support only 1771 digital I/O modules.

Display Devices	EtherNet/IP	ControlNet	DeviceNet	DH+	Universal Remote I/O	RS-232 (DF1)	DH-485
2711P PanelView Plus terminal	yes	yes	yes	yes	yes	yes	no*
6182H VersaView CE computer	yes	yes	yes	yes	yes	yes	no*
2711 PanelView terminal	yes	yes	yes	yes†	yes	yes†	yes†
2711 e PanelView terminal	no	yes	no	yes†	yes	no	no
2705 RediSTATION/Re diPANEL operator module	no	no	yes	no	yes	no	no
2706 InView message display	yes	yes	yes	yes	yes	yes	yes
2706 DL40 Dataliner message display	no	no	no	no	yes	yes	no
2706 DL, DL50 DataLiner message display	no	no	no	no	no	yes	no
2707 DTAM Plus operator interface	no	no	yes	no	yes	yes†	yes†

*These devices support DH-485 communication to FlexLogix and CompactLogix controllers.

†Use PLC/SLC mapping.

Communicating with Other Controllers and Communication Devices

The ControlLogix system takes advantage of several networks to allow communications with many different controllers and devices. The following table lists which products the ControlLogix controller can communicate with over which networks.

Controller	EtherNet/IP	ControlNet	DeviceNet	DH+	RS-232 (DF1)	DH-485
1756 ControlLogix	yes	yes	yes	yes	yes	yes
1769 CompactLogix	yes	no	yes	no	yes	yes
1789 SoftLogix5800	yes	yes	yes	no	yes	no
1794 FlexLogix	yes	yes	yes	no	yes	yes
5720 PowerFlex 700S with DriveLogix	yes	yes	yes	no	yes	yes
1785 PLC-5	yes*†	yes	yes‡	yes	yes	na
1747 SLC	yes§	yes	yes♣	yes♣	yes	no
1761 MicroLogix	yes	no	yes♣	no	yes	no
1762 MicroLogix	yes	no	yes♣	no	yes	no
1769 MicroLogix	yes	no	yes♣	no	yes	no
1772 PLC-2	na	na	na	yes➤	yes⌘	na
1775 PLC-3	na	na	na	yes✦	yes❖	na
5250 PLC-5/250	na	na	no	yes	yes	na

*The Ethernet PLC-5 processor must be one of these:

series C, revision N.1 or later
series D, revision E.1 or later
series E, revision D.1 or later

†The 1785-ENET Ethernet communication interface module must be series A, revision D or later.

‡The PLC-5, SLC, and MicroLogix processors appear as I/O points to the Logix controller. Requires 1761-NET-DNI DeviceNet interface.

§Use a 1747-L55x controller with OS501 or greater.

♣Use a 1747-L54x controller.

➤The PLC-2 controller requires a 1785-KA module for DH+ communications.

⌘The PLC-2 controller requires a 1771-KG module for serial (DF1) communications.

✦The PLC-3 controller requires a 1775-S5 module for DH+ communications.

❖The PLC-3 controller requires a 1775-KA module for serial (DF1) communications.

Communication Device	EtherNet/IP	ControlNet	DeviceNet	DH+	RS-232 (DF1)	DH-485
9355 RSLinx software	yes	yes	no	yes	yes	no
1784-KTC, -KTCx, -KTCx15, -PCIC(S), -PCC	na	yes	na	na	na	na
1784-PCIDS, -PCD	na	na	yes	na	na	na
1784-KTX, -KTXD, -PCMK	na	na	na	yes	na	na
1788-CN2DN	na	yes	yes	na	na	na
1788-EN2DN	yes	na	yes	na	na	na
1788-CN2FF	na	yes	na	na	na	na
1203-CN1 ControlNet module	na	yes*	na	na	na	na
1203-FM1/FB1 SCANport	na	yes†	na	na	na	na

*Use the generic module configuration to configure the 1203-CN1 module and a CIP generic MSG instruction to communicate with the module.

†Use a CIP generic MSG instruction to communicate with the 1203-FM1 SCANport module on a DIN rail that is remote to the controller. The remote DIN rail also requires a 1794-ACN(R)15 ControlNet adapter module.

Communicating with Drives

The ControlLogix system takes advantage of several networks to allow communications with many different drives, both motion (servo) drives and standard drives. The following table lists which drives the ControlLogix controller can communicate with over which networks.

Motion (Servo) Drives*	EtherNet/IP	ControlNet	DeviceNet	DH+	RS-232	DH-485
1394 GMC drive and control	no	no	no	yes	yes	yes
1398 ULTRA 100 series drive	no	no	yes	no	no	no
2098 Ultra3000 DeviceNet servo drive	no	no	yes	no	no	no
2098 Ultra5000 intelligent positioning	no	no	yes	no	yes	no

*Each drive has different options you order for its supported communication networks. See the appropriate catalog or selection information for a drive to make sure you select the appropriate option when specifying a drive for a specific network.

Standard Drives*	EtherNet/IP	ControlNet	DeviceNet	DH+	RS-232	DH-485
1305 adjustable frequency ac drive	no	yes	yes	yes	yes	yes
1336 adjustable frequency ac drive	no	yes	yes	yes	yes	yes
1395 digital dc drive	no	yes	no	yes	yes	no
FlexPak 3000 dc drive	no	yes	yes	no	yes	no
WebPak 3000 dc winder	no	yes	no	no	yes	no
GV3000 ac drive	no	yes	yes	no	yes	no
PowerFlex 40 ac drive	no	no	yes	no	yes	yes
PowerFlex 70, 700, 700S, and 7000 ac drive	yes	yes	yes	yes	yes	yes

*Each drive has different options you order for its supported communication networks. See the appropriate catalog or selection information for a drive to make sure you select the appropriate option when specifying a drive for a specific network.

How a Logix System Uses Tasks

A Logix controller uses three types of tasks. Use the following table to choose the appropriate type of task for each section of your logic.

If you want to execute a section of your logic:	Then use this type of task:	Description:
all of the time	Continuous Task	<p>The continuous task runs in the background. Any CPU time not allocated to other operations (such as motion, communications, and periodic or event tasks) is used to execute the programs within the continuous task.</p> <ul style="list-style-type: none"> • The continuous task runs all the time. When the continuous task completes a full scan, it restarts immediately. • A project does not require a continuous task. If used, there can be only one continuous task.
<ul style="list-style-type: none"> • at a constant period (e.g., every 100 ms) • multiple times within the scan of your other logic 	Periodic Task.	<p>A periodic task performs a function at a specific period.</p> <ul style="list-style-type: none"> • Whenever the time for the periodic task expires, the task interrupts any lower priority tasks, executes one time, and then returns control to where the previous task left off. • You can configure the time period from 0.1 ms to 2000 msec. The default is 10 ms. It is also controller and configuration dependent. • The performance of a periodic task depends on the type of Logix controller and on the logic in the task.
immediately when an event occurs	Event Task	<p>An event task performs a function only when a specific event (trigger) occurs.</p> <p>The trigger for the event task can be:</p> <ul style="list-style-type: none"> • change of a digital input • new sample of analog data • certain motion operations • consumed tag • EVENT instruction <p>Whenever the trigger for the event task occurs, the event task:</p> <ul style="list-style-type: none"> • interrupts any lower priority tasks • executes one time • returns control to where the previous task left off

Event tasks

Several factors affect the closed-loop event throughput:

- input module type, filter time, and response time
- backplane size and loading
- controller type, configuration, and loading
- output module type and response time

To use a device to trigger an event task, the device must support event task triggering. If the device is in a remote location, the associated communication modules must also support event triggering. These devices support input events:

Category	Modules	
Digital I/O modules that support change of state	1756-IA8D	1756-IA16
	1756-IA16I	1756-IA32
	1756-IB16	1756-IB16D
	1756-IB16I	1756-IB16ISOE
	1756-IB32/A	1756-IB32/B
	1756-IC16	1756-IG16
	1756-IH16I	1756-IH16ISOE
	1756-IM16I	1756-IN16
	1756-IV16/A	1756-IV32/A
	Analog I/O modules that support real time sample	1756-IF16
1756-IF6CIS		1756-IF6I
1756-IF8		1756-IR6I
1756-IT6I		1756-IT6I2
Specialty I/O modules	1756-CFM/A	1756-HSC
	1756-PLS/B	
Communication modules that provide rack-optimized connections	1756-CNB/A	1756-CNB/B
	1756-CNB/D	1756-CNBR/A
	1756-CNBR/B	1756-CNBR/D
	1756-DNB	1756-ENBT/A
	1756-SYNCH/A	1784-PCIDS/A
Generic I/O modules that conform to CIP event communications	1756-MODULE	
	1789-MODULE	

When planning for event tasks, consider these recommendations:

Recommendation	Details
Place the module that triggers an event in the same chassis as the controller.	Placing a module in a remote chassis adds additional network communications and processing to the response time.
Limit number of modules in the chassis with the event module and the controller.	Additional modules increases the potential for backplane delays.
Limit events on digital inputs to a single input bit on a module.	All inputs on a module trigger a single event so using multiple bits increases the chances of a task overlap. Configure the module to explicitly detect change-of-state on the input and turn off the other bits.
The priority of the event task should be set as the highest priority on the controller.	Setting an event task at a lower priority than a periodic task will force the event task to wait for the periodic task to complete execution.
Limit the number of event tasks.	Increasing the number of event tasks reduces the available CPU bandwidth and increases the chance of a task overlap.
The 1756-IB32/B and 1756-IF4FXOF2F are recommended for digital and analog events.	These modules have the best response times.

Estimating event task throughput

To estimate the throughput time from input to output (screw to screw), use the following worksheet:

Consideration:	Value (in μs):
1. What is the input filter time of the module that triggers the event task?	
This is typically shown in milliseconds, Convert it to microseconds (μs).	
2. What is the hardware response time for the input module that triggers the event task?	
Make sure you use the appropriate type of transition (Off to On or On to Off). See the following table.	
3. What is the backplane communication time?	
If the chassis size is: Use this value (worst case): 4 slot 13 μs 7 slot 22 μs 10 slot 32 μs 13 slot 42 μs 17 slot 54 μs	
4. What is the total execution time of the programs in the event task?	
5. What is the backplane communication time (same value as step 3).	
6. What is the hardware response time of the output module?	
7. Add steps 1 through 6. This is the minimum estimated throughput, where execution of the motion planner or other tasks do not delay or interrupt the event task.	
8. What is the scan time of the motion group?	
9. What is the total scan time of the tasks that have a higher priority than this event task (if any)?	
10. Add steps 7 through 9. This is the nominal estimated throughput, where execution of the motion planner or other tasks delay or interrupt the event task.	

Use the following table to determine the nominal hardware response time for selected 1756 I/O modules.

Module:	Nominal response time μs :			
	25° C		60° C	
	Off to On	On to Off	Off to On	On to Off
1756-IB16	265	582	265	638
1756-IB16D	303	613	305	673
1756-IB32	330	359	345	378
1756-IV16	257	435	254	489
1756-IV32	381	476	319	536
1756-OB16D	48	519	51	573
1756-OB16E	60	290	61	324
1756-OB32	38	160	49	179
1756-OV16E	67	260	65	326
1756-OV32E	65	174	66	210

How a Logix System Uses Connections

A Logix system uses a connection to establish a communication link between two devices. Connections can be:

- controller to local I/O modules or local communication modules
- controller to remote I/O or remote communication modules
- controller to remote I/O (rack optimized) modules
- produced and consumed tags
- messages

You indirectly determine the number of connections the controller uses by configuring the controller to communicate with other devices in the system.

Connections are allocations of resources that provide more reliable communications between devices than unconnected messages. A Logix system supports:

Method	Description
scheduled connection <ul style="list-style-type: none"> • level of determinism • unique to ControlNet 	A scheduled connection is unique to ControlNet communications. A scheduled connection lets you send and receive data repeatedly at a predetermined interval, which is the requested packet interval (RPI). For example, a connection to an I/O module is a scheduled connection because you repeatedly receive data from the module at a specified interval. Other scheduled connections include connections to: <ul style="list-style-type: none"> • communication devices • produced/consumed tags On a ControlNet network, you must use RSNetWorx for ControlNet to enable all scheduled connections and establish a network update time (NUT).
unscheduled connection <ul style="list-style-type: none"> • deterministic • used by both ControlNet and EtherNet/IP 	An unscheduled connection is a message transfer between controllers that is triggered by the requested packet interval (RPI) or the program (such as a MSG instruction). Unscheduled messaging lets you send and receive data when needed. All EtherNet/IP connections are unscheduled.
unconnected message <ul style="list-style-type: none"> • least deterministic 	An unconnected message is a message that does not require connection resources. An unconnected message is sent as a single request/response.

The communication module you select determines the number of connections you have available for I/O and messages.

This communication module:	Supports this number of connections:
1756-CNB	64 (any combination of scheduled and unscheduled)
1756-ENBT	128 (any combination of scheduled and unscheduled) The EtherNet/IP module does not distinguish between scheduled and unscheduled connections.

How you configure connections determines how many remote devices a communication card can support.

Determining Connections for Produced and Consumed Tags

The controller supports the ability to produce (broadcast) and consume (receive) system-shared tags over ControlNet or EtherNet/IP networks. Produced and consumed tags each require connections. Over ControlNet, produced and consumed tags are scheduled connections.

This type of tag:	Requires these connections:
produced	<p>A produced tag allows other controllers to consume the tag, which means that a controller can receive the tag data from another controller. The local controller (producing) uses one connection for the produced tag and one connection for each consumer. The controller's communication device uses one connection for each consumer.</p> <p>As you increase the number of controllers that can consume a produced tag, you also reduce the number of connections the controller and communication device have available for other operations, like communications and I/O.</p>
consumed	Each consumed tag requires one connection for the controller that is consuming the tag. The controller's communication device uses one connection for each consumer.

For two controllers to share produced or consumed tags, both controllers must be attached to the same control network (such as a ControlNet or Ethernet/IP network). You cannot bridge produced and consumed tags over two networks.

The total number of tags that can be produced or consumed is limited by the number of available connections. If the controller uses all of its connections for I/O and communication devices, no connections are left for produced and consumed tags.

Maximum number of produced and consumed tags

The controller supports:

As a:	The controller supports:
producer	(number of produced tags) \leq 127
consumer	(number of consumed tags) \leq 250

The total combined consumed and produced tags that a controller supports is (this is also the maximum number of connections):

$$(\text{number of produced tags}) + (\text{number of consumed tags}) \leq 250$$

Determining Connections for Messages

Messages transfer data to other devices, such as other controllers or operator interfaces. Some messages use unscheduled connections to send or receive data. These connected messages can leave the connection open (cache) or close the connection when the message is done transmitting. The following table shows which messages use a connection and whether or not you can cache the connection:

This type of message:	Using this communication method:	Uses a connection:
CIP data table read or write	CIP	✓
PLC2, PLC3, PLC5, or SLC (all types)	CIP	
	CIP with Source ID	
	DH+	✓
CIP generic	CIP	your option*
block-transfer read or write	na	✓

*You can connect CIP generic messages, but for most applications we recommend you leave CIP generic messages unconnected.

Connected messages are unscheduled connections on both ControlNet and EtherNet/IP networks.

Each message uses one connection, regardless of how many devices are in the message path. To conserve connections, you can configure one message to read from or write to multiple devices.

If a message executes repeatedly, cache the connection. This keeps the connection open and optimizes execution time. Opening a connection each time the message executes increases execution time.

If a message executes infrequently, do not cache the connection. This closes the connection upon completion of the message, which frees up that connection for other uses.

A Logix system uses connections to transmit I/O data. These connections can be direct connections or rack-optimized connections.

Determining Connections for I/O Modules

A Logix system uses connections to transmit I/O data. These connections can be direct connections or rack-optimized connections.

Connection	Description
direct	A direct connection is a real-time, data transfer link between the controller and an I/O module. The controller maintains and monitors the connection between the controller and the I/O module. Any break in the connection, such as a module fault or the removal of a module while under power, causes the controller to set fault status bits in the data area associated with the module. Typically, analog I/O modules and specialty modules require direct connections.
rack-optimized	For digital I/O modules, you can select rack optimized communication. A rack optimized connection consolidates connection usage between the controller and all the digital I/O modules on a rack (or DIN rail). Rather than having individual, direct connections for each I/O module, there is one connection for the entire rack (or DIN rail).

Depending on the type of I/O modules, both direct connections and rack-optimized connections can be used.

I/O System	Supported Connection Type(s):
1756 basic digital I/O in a local chassis	direct connection
digital I/O in a remote chassis via ControlNet	direct connection or rack-optimized connection*
analog I/O either in a local chassis or in a remote chassis via ControlNet	direct connection
digital I/O in a remote chassis via EtherNet/IP	direct connection or rack-optimized connection*
analog I/O in a remote chassis via EtherNet/IP	direct connection
digital I/O via Universal Remote I/O	rack-optimized connection
analog I/O via Universal Remote I/O	direct connection via messaging
1771 analog I/O via ControlNet	direct connection via messaging
DeviceNet I/O	rack-optimized connection

*Rack-optimized connections for diagnostic and E-fuse modules do not send diagnostic or fuse data to controller.

Considerations:

Connection configuration	Details
Direct connections to 1756 I/O modules	The controller can have a direct connection to every I/O module in a remote chassis on an EtherNet/IP or ControlNet network. Because all the remote I/O modules are configured for direct connections, configure the remote communication module for “none,” which results in no connection.
Rack-optimized connections to 1756 I/O modules	Rather than one connection to each remote I/O module, use one connection to communicate with all the digital I/O in the remote chassis (each analog I/O module requires a direct connection). The data from all the digital I/O modules is sent simultaneously at a rate specified by the remote connection through the EtherNet/IP or ControlNet communication module. The rack-optimized connection conserves connections and bandwidth. However, because the connections are condensed into one rack connection, the optimized digital I/O can no longer send all of its status and diagnostic data.
Combining direct and rack-optimized connections	A remote ControlLogix chassis can have both a rack-optimized connection and direct connections. Use a rack-optimized connection to consolidate all the digital I/O modules. Use a direct connection for each analog I/O module.
Connections to DeviceNet devices	The controller uses two connections to communicate with the 1756-DNB module. The 1756-DNB module does not establish connections to its devices; and therefore, the controller doesn't establish connections with DeviceNet devices. The 1756-DNB module acts as a scanner that gathers all the data from its devices and packs that data together into one image that is passed to the controller. However, the controller can use a MSG instruction to get information directly to or from a DeviceNet device.
Connections to 1771 I/O modules	The controller communicates with a 1771 chassis through a 1756-DHRIO module to the adapter module of the 1771 chassis. The controller uses one connection for each logical rack. The addressing mode (1/2 slot, 1 slot, or 2 slot) of the 1771 chassis determines the number of logical racks, which determines the total number of connections. In addition, the controller uses one connection for each message to a 1771 block-transfer module.

Connections Example

In this example system the 1756 ControlLogix controller:

- controls local (in the same chassis) digital I/O modules
- controls remote I/O devices on DeviceNet
- sends and receives messages to/from the 1769-L35E CompactLogix controllers on EtherNet/IP
- produces one tag that the 1794 FlexLogix controller consumes
- is programmed via RSLogix 5000 programming software

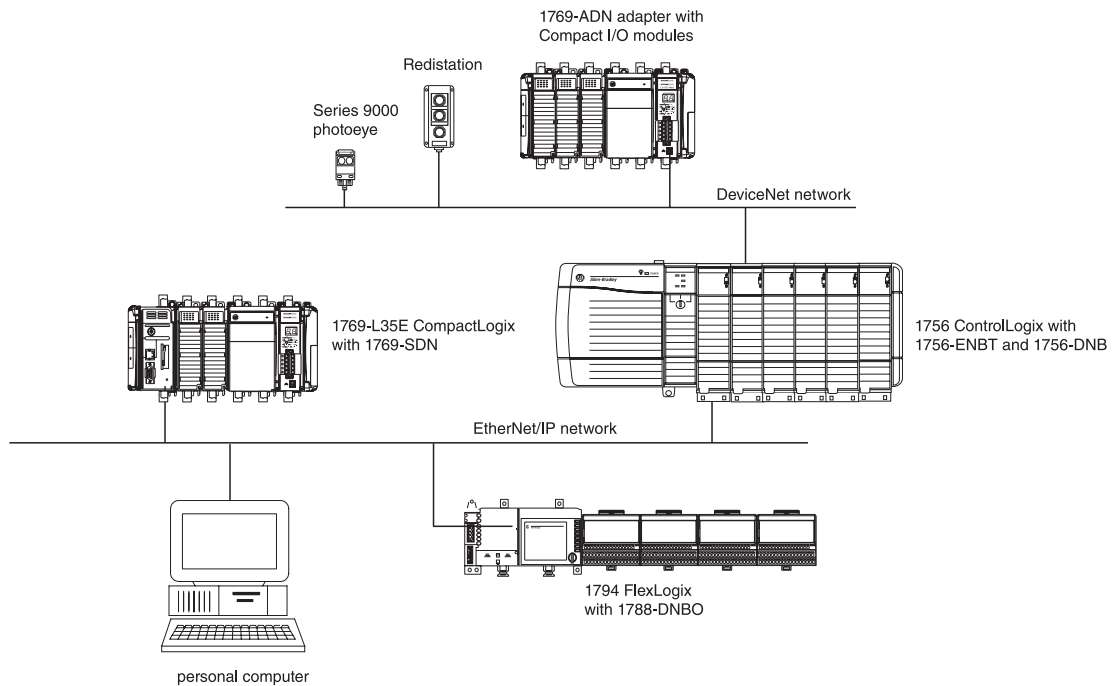

The 1756 ControlLogix controller in this example uses these connections:

Connection Type	Module Quantity	Connections per Module	Total Connections
controller to local I/O modules (rack-optimized)	4	1*	1
controller to 1756-ENBT module (rack-optimized)	1	0	0
controller to 1756-DNB module	1	2	2
controller to RSLogix 5000 programming software	1	1	1
message to 1769-L35E CompactLogix controller	1	1	1
produced tag consumed by 1794 FlexLogix controller	1	1	1
total			6

*A rack-optimized connection uses 1 connection for all the associated modules.

Determining Total Connection Requirements

The ControlLogix controller supports 250 connections. To calculate the total connections for a controller, consider the connections to local I/O modules and the connections to remote modules.

Use the following table to tally **local** connections:

Connection Type	Device Quantity	Connections per Device	Total Connections
local I/O module (always a direct connection)		1	
1756-M16SE, -M08SE, -M02AE servo module		3	
1756-CNB, -CNBR communication module		0	
1756-ENBT communication module		0	
1756-DNET communication module		2	
1756-DHRIO communication module		1	

Regardless of how you configure local I/O modules (rack-optimized or direct connect), the controller establishes a direct connection for each local I/O module.

Remote connections depend on the communication module. The number of connections the module itself supports determines how many connections the controller can access through that module. Use the following table to tally **remote** connections for the controller:

Connection Type	Device Quantity	Connections per Device	Total Connections
remote 1756-CNB, -CNBR ControlNet communication module configured as a direct (none) connection		0 or 1	
remote 1756-CNB, -CNBR ControlNet communication module configured as a rack-optimized connection			
remote I/O module over ControlNet (direct connection)		1	
remote 1756-ENBT Ethernet communication module configured as a direct (none) connection		0 or 1	
remote 1756-ENBT Ethernet communication module configured as a rack-optimized connection			
remote I/O module over EtherNet/IP (direct connection)		1	
remote device over DeviceNet (accounted for in rack-optimized connection for local 1756-DNB module)		0	
other remote communication adapter		1	
produced tag		1	
each consumer		1	
consumed tag		1	
cached message		1	
block-transfer message		1	
total			

Step 5 - Select:

- a chassis with sufficient slots
- 1756-N2 filler strips for empty slots

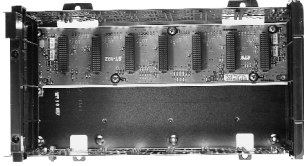

Selecting Chassis

The ControlLogix system is a modular system that requires a 1756 I/O chassis to contain the various modules. Chassis are available in sizes of 4, 7, 10, 13, and 17 module slots. You can place any module into any slot.

The backplane provides a high-speed communication path between modules. Multiple controller modules on the backplane can pass messages between one another. With multiple communication interface modules on the backplane, a message can be sent from across a link into a port on one module, routed across the backplane and out another module's port, and sent across another link to its ultimate destination.

Cat. No.	Slots	Weight	Dimensions (HxWxD)	Minimum Cabinet Size (HxWxD)	Maximum Backplane Current Load
1756-A4	4	0.75 kg (1.7 lb)	137 x 263 x 145 mm (5.4 x 10.4 x 5.8 in)	508 x 508 x 203 mm (20 x 20 x 8 in)	4.0A @ 3.3V dc 15.0A @ 5V dc 2.8A @ 24V dc
1756-A7	7	1.10 kg (2.4 lb)	137 x 368 x 145 mm (5.4 x 14.5 x 5.8 in)	508 x 610 x 203 mm (20 x 24 x 8 in)	
1756-A10	10	1.45 kg (3.2 lb)	137 x 483 x 145 mm (5.4 x 19.0 x 5.8 in)	508 x 762 x 203 mm (20 x 30 x 8 in)	
1756-A13	13	1.90 kg (4.2 lb)	137 x 588 x 145 mm (5.4 x 23.2 x 5.8 in)	610 x 762 x 203 mm (24 x 30 x 8 in)	
1756-A17	17	2.20 kg (4.8 lb)	137 x 738 x 145 mm (5.4 x 29.1 x 5.8 in)	762 x 914 x 203 mm (30 x 36 x 8 in)	

Certifications: UL, CSA (Class 1, Division 2, Group A, B, C, D), CE, FM

All the chassis are designed for back-panel mounting. Use the slot filler module 1756-N2 to fill empty slots.

When you mount a chassis in an enclosure, make sure to meet these minimum spacing requirements:

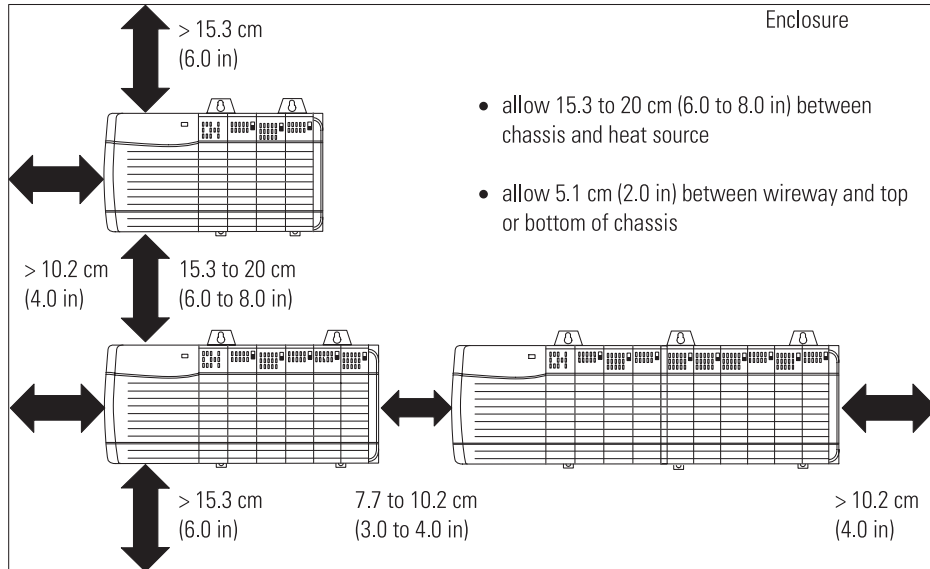

Mounting dimensions

right-side view of all chassis

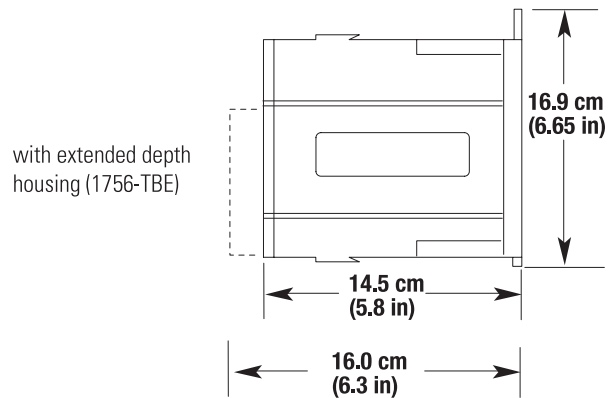

1756-A4 with power supply

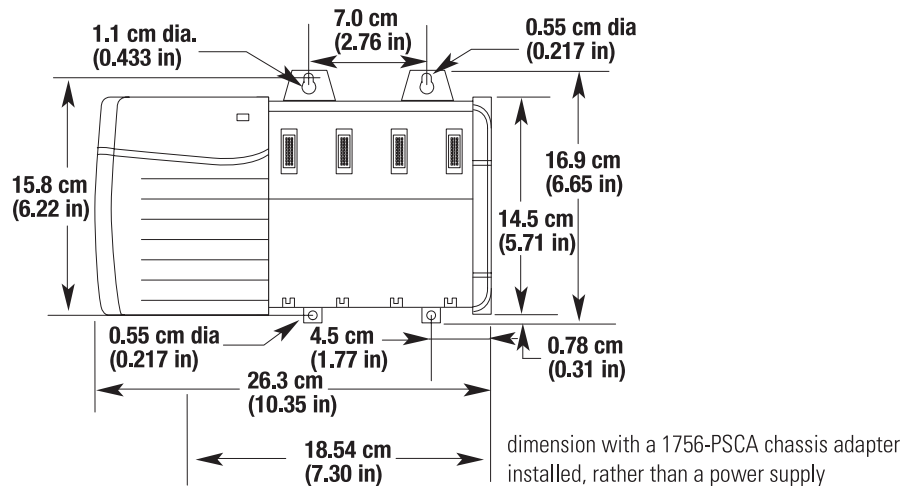

1756-A7 with power supply

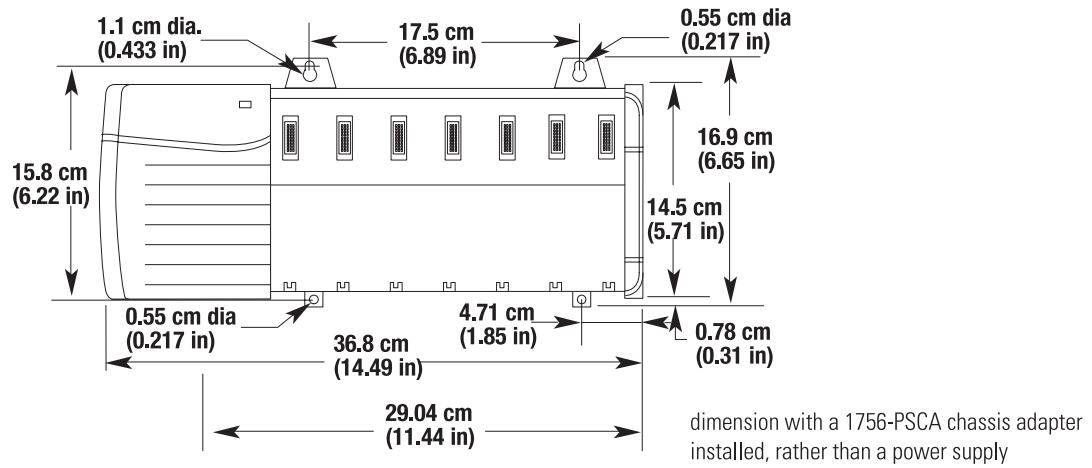

1756-A10 with power supply

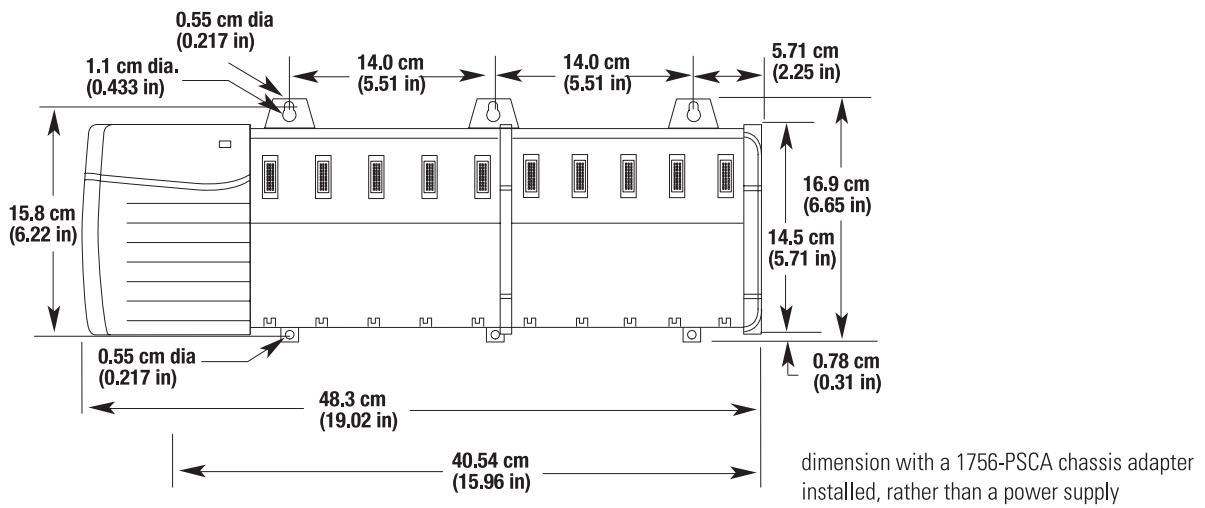

1756-A13 with power supply

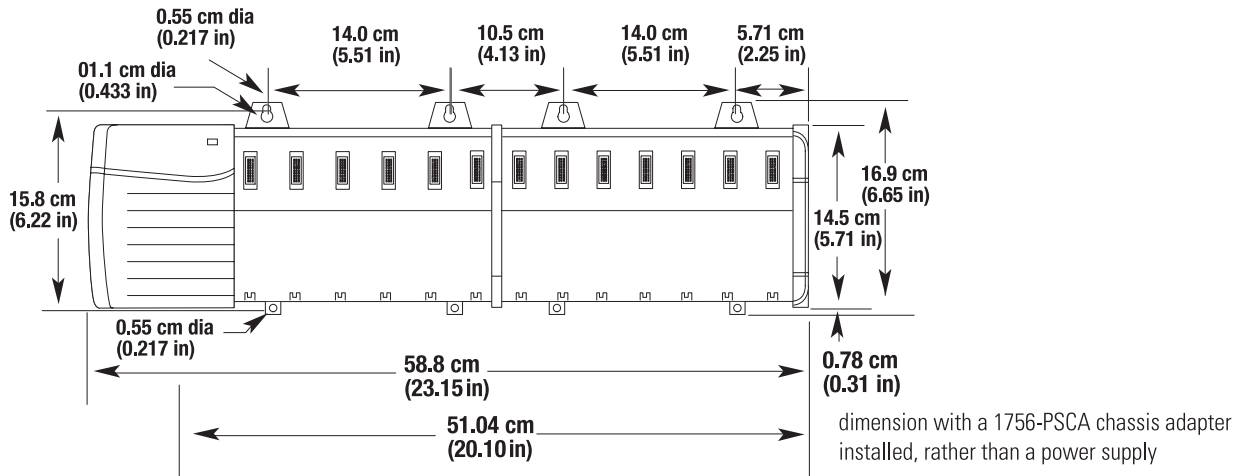

1756-A17 with power supply

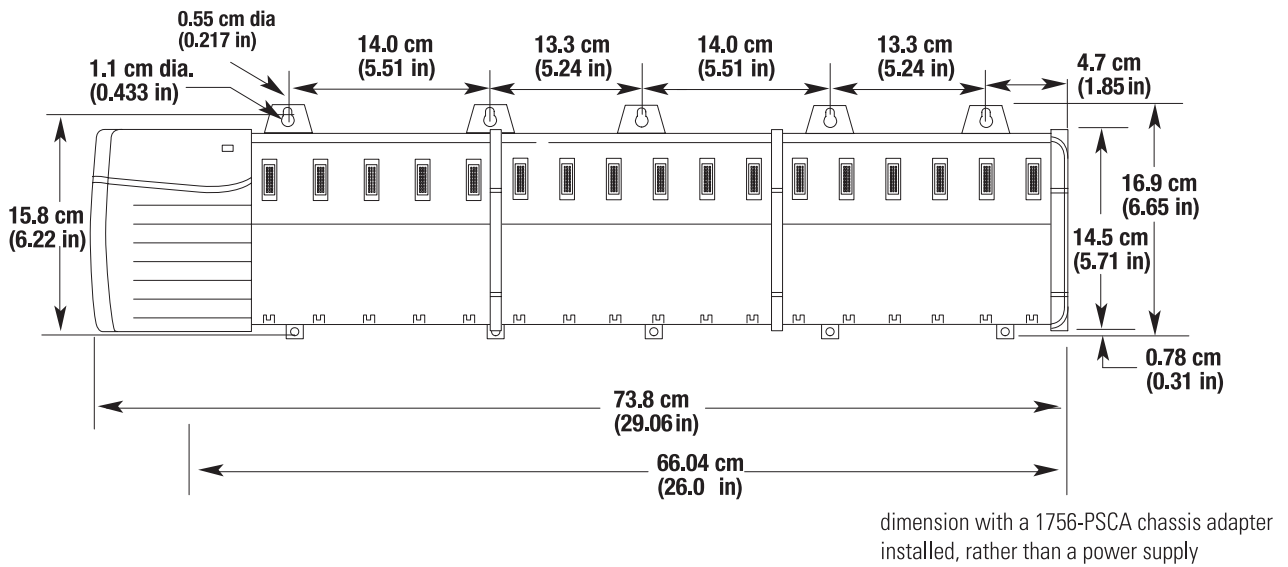

Step 6 - Select:

- *one power supply for each chassis*
- *a power supply bundle if you are planning a redundant power supply system*

Selecting Power Supplies

ControlLogix power supplies are used with the 1756 chassis to provide 1.2V, 3.3V, 5V, and 24V dc power directly to the chassis backplane. Non-redundant (1756-PA72, -PB72, -PA75, -PB75) and redundant (1756-PA75R, -PB75R) power supplies are available.

Selecting a standard power supply

You mount a standard power supply directly on the left end of the chassis, where it plugs directly into the backplane. The power supply you select can determine which chassis you can use.

Specification	Power Supplies					
	1756-PA72	1756-PA75	1756-PB72	1756-PB75	1756-PC75	1756-PH75
Nominal Input Voltage	120V ac or 220V ac		24V dc		48V dc	125V dc
Input Voltage Range	85...265V ac		19...32V dc		30...60V dc	90...143V dc
Maximum Real Input Power	95 W		97 W		98 W	95 W
Maximum Apparent Input Power	240 VA		na		na	na
Maximum Transformer Load	238 VA		na		na	na
Input Frequency	47...63 Hz		dc		dc	dc
Maximum Backplane Output Current	1.5A @ 1.2V dc 4A @ 3.3V dc 10A @ 5V dc 2.8A @ 24V dc 75W total	1.5A @ 1.2V dc 4A @ 3.3V dc 13A @ 5V dc 2.8A @ 24V dc 75W total	1.5A @ 1.2V dc 4A @ 3.3V dc 10A @ 5V dc 2.8A @ 24V dc 75W total	1.5A @ 1.2V dc 4A @ 3.3V dc 13A @ 5V dc 2.8A @ 24V dc 75W total	1.5A @ 1.2V dc 4A @ 3.3V dc 13A @ 5V dc 2.8A @ 24V dc 75W total	1.5A @ 1.2V dc 4A @ 3.3V dc 13A @ 5V dc 2.8A @ 24V dc 75W total
Hold Up Time*	60 Hz 85V ac: 2 cycles 120V ac: 6 cycles 220V ac: 20 cycles		20ms @ 19V dc 70ms @ 24V dc		50 ms @ 30...60V dc	50ms @ 90...143V dc
Chassis Compatibility	series A series B	series B	series A series B	series B	series B	series B
Location	left side of chassis		left side of chassis		left side of chassis	left side of chassis

Certifications: UL, CSA (Class 1, Division 2, Group A, B, C, D), CE, FM, C-Tick

*The hold up time is the time between input voltage removal and dc power failure.

†This can be a maximum of 0.91 cable-metered (3 cable feet) from the ControlLogix chassis.

Selecting a redundant power supply

To build a redundant power supply system, you need:

- two redundant power supplies (both 1756-PA75R or 1756-PB75R)
- one 1756-PSCA2 chassis adapter module
- two 1756-CPR2 cables to connect the power supplies to the 1756-PSCA2 chassis adapter module (3 ft length)
- user-supplied annunciator wiring to connect the power supplies to the input modules, as needed

Specification	Power Supplies		Adapter
	1756-PA75R	1756-PB75R	1756-PSCA2
Nominal Input Voltage	120V/220V ac	24V dc	na
Input Voltage Range	85...265V ac	19...32V dc	
Maximum Real Input Power	115 W	110 W	
Maximum Apparent Input Power	120 VA	na	
Maximum Transformer Load	120 VA	na	
Input Frequency	47...63 Hz	dc	
Maximum Backplane Output Current	1.5A @ 1.2V dc 4A @ 3.3V dc 13A @ 5V dc 2.8A @ 24V dc 75W total	1.5A @ 1.2V dc 4A @ 3.3V dc 13A @ 5V dc 2.8A @ 24V dc 75W total	
Hold Up Time*	60 Hz 85V ac: 2 cycles 120V ac: 6 cycles 220V ac: 20 cycles	20ms @ 19V dc 70ms @ 24V dc	na
Chassis Compatibility	series B	series B	series B
Location	panel mounted†	panel mounted†	left side of chassis

Certifications: UL, CSA (Class I, Division 2, Group A, B, C, D), CE, FM, C-Tick

*The hold up time is the time between input voltage removal and dc power failure.

†This can be a maximum of 0.91 cable-metered (3 cable feet) from the ControlLogix chassis.

The 1756-PSCA2 chassis adapter module is a passive device that funnels power from the redundant power supplies to the single power connector on the ControlLogix series B chassis backplane.

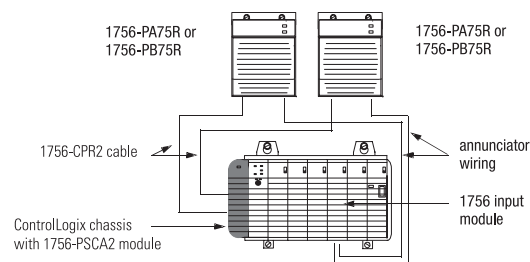

The redundant power supplies are available in ac (1756-PA75R) and dc (1756-PB75R) versions. They are also available in bundled systems:

Redundant Power Supply Bundle	Contents
1756-PAR2	<ul style="list-style-type: none"> • two 1756-PA75R power supplies • two 1756-CPR2 cables • one 1756-PSCA2 chassis adapter module
1756-PBR2	<ul style="list-style-type: none"> • two 1756-PB75R power supplies • two 1756-CPR2 cables • one 1756-PSCA2 chassis adapter module

Power Requirements and Transformer Sizing

Each ac-input power supply generates a shutdown signal on the backplane whenever the ac line voltage drops below its lower voltage limit. It removes the shutdown signal when the line voltage comes back up to the lower voltage limit. This shutdown is necessary to help ensure that only valid data is stored in memory.

The external transformer rating (in VA) of each power supply is greater than its real input power (in Watts) because a capacitor-input ac/dc supply draws power only from the peak of the ac voltage wave form. If the transformer is too small, it clips the peak of the sine wave; when the voltage is still above the lower voltage limit, the power supply will sense this clipped wave form as low voltage and could prematurely shut down modules in the chassis.

The following graphs display the backplane power load on the vertical axis. Since these supplies have multiple outputs, the backplane power load is given in watts.

- Use the real power value in watts for determining the amount of heat dissipation you will have inside the enclosure.
- Use the apparent power value in VA for estimating power distribution sizing.
- Use the transformer load value in VA of each power supply plus all other loads on a transformer to determine the required transformer size.

Power load and transformer sizing

1756-PA72
1756-PA75
ac

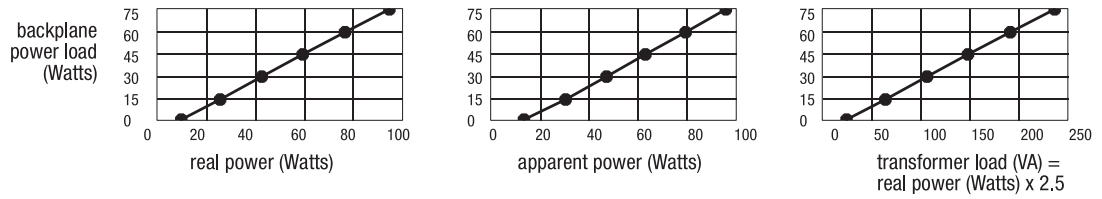

1756-PA75R
ac

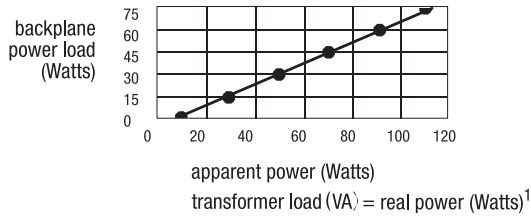

1756-PB72
1756-PB75
dc

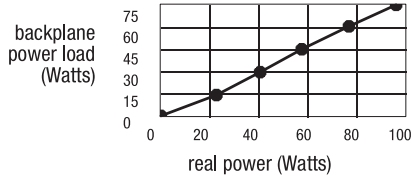

1756-PB75R
dc

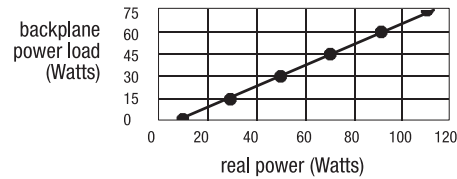

1756-PC75
1756-PH75
dc

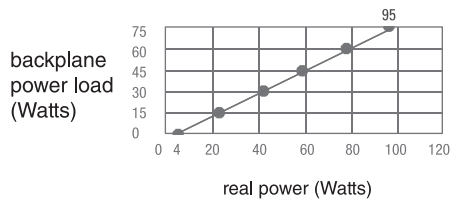

Step 7 - Select:

- *the appropriate package of RSLogix 5000 Enterprise Series software and any options*
- *other software packages for your application*

Selecting Software

Your selection of modules and network configuration determines what software packages you need to configure and program your system.

If you have a:	You need:	Order this catalog number:
1756 ControlLogix controller 1756 SERCOS or analog motion module	RSLogix 5000 Enterprise Series software	9324 series (RSLogix 5000 Enterprise Series software)
1756-CNB, -CNBR ControlNet communication module	RSNetWorx for ControlNet (comes with the standard/NetWorx option of RSLogix 5000 Enterprise Series software)	9324-RLD300NXENE (RSLogix 5000 Enterprise Series software plus RSNetWorx option) or 9357-CNETL3 (RSNetWorx for ControlNet)
1756-DNB DeviceNet communication module	RSNetWorx for DeviceNet (comes with the standard/NetWorx option of RSLogix 5000 Enterprise Series software)	9324-RLD300NXENE (RSLogix 5000 Enterprise Series software plus RSNetWorx option) or 9357-DNETL3 (RSNetWorx for DeviceNet)
1756-ENBT, -ENET EtherNet/IP communication module (set the IP address) 1756-DHRIO communication module (define the DH+ routing table)	RSLinx software (RSLinx Lite and Bootp server come with RSLogix 5000 Enterprise Series software)	9324 series (RSLogix 5000 Enterprise Series software)
1788-CN2FF FoundationFieldbus linking device	Foundation Fieldbus Configuration Software and RSLinx or RSLinx OEM software (RSLinx Lite is not sufficient)	1788-FFCT and 9355-WABENE or 9355-WABOEMENE
1757-FFLD FoundationFieldbus linking device	RSFieldbus configuration software	9324-RSFBC
communication card in a workstation	RSLinx software (RSLinx Lite comes with RSLogix 5000 Enterprise Series software)	9324 series (RSLogix 5000 Enterprise Series software)
Logix-based system you want to emulate	RSLogix Emulate 5000	9310-WED200ENE
Logix-based system for which you want training	RSTrainer 2000 for ControlLogix Fundamentals	9393 series
operator interface	RSView Enterprise series software	ViewAnyWare products

Programming Software

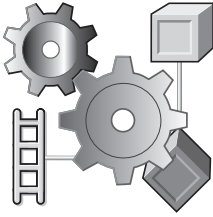

RSLogix 5000 Enterprise Series software is designed to work with Rockwell Automation's Logix platforms. RSLogix 5000 Enterprise Series software is an IEC 61131-3 compliant software package that offers relay ladder, structured text, function block diagram, and sequential function chart editors for you to develop application programs. RSLogix 5000 Enterprise Series software also includes axis configuration and programming support for motion control.

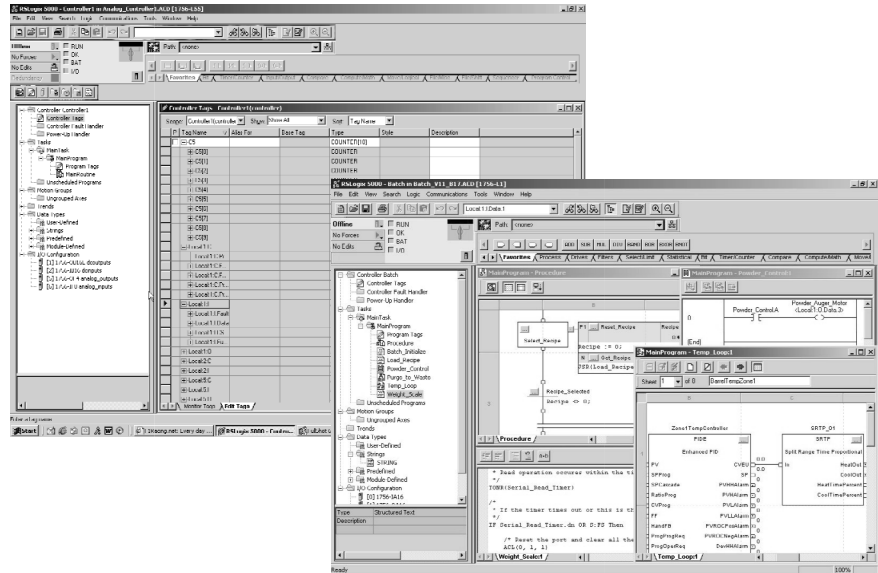

RSLogix 5000 Enterprise Series software requirements

Description	Value
personal computer	Pentium II 450 MHz minimum Pentium III 733 MHz (or better) recommended
software requirements	Supported operating systems: <ul style="list-style-type: none"> • Microsoft Windows XP Professional version 2002 (with Service Pack 1) or XP Home version 2002 • Microsoft Windows 2000 Professional with Service Pack 1, 2, or 3 • Microsoft Windows NT version 4.0 with Service Pack 5 or 6A
RAM	128 Mbytes of RAM minimum 256 Mbytes of RAM recommended
hard disk space	100 Mbytes of free hard disk space (or more based on application requirements)
video requirements	256-color VGA graphics adapter 800 x 600 minimum resolution (True Color 1024 x 768 recommended)

Selecting the programming package

Available Features	Service Edition 9324- RLD000xxE*†	Mini Edition 9324- RLD200xxE*	Lite Edition 9324- RLD250xxE*	Standard Edition 9324-RLD300xxE*	Standard/ NetWorx Edition 9324- RLD300NXxxE*	Full Edition 9324- RLD600xxE*‡	Professional Edition 9324- RLD700NXxxE*
Logix5000 controllers supported	all	CompactLogix5300 FlexLogix5400	CompactLogix5300 FlexLogix5400	all	all	all	all
Relay ladder editor§	view only	fully supported	fully supported	fully supported	fully supported	fully supported	fully supported
Function block diagram editor 9324-RLDFBDENE§	view only	upload/download only editor available separately	fully supported	upload/download only editor available separately	upload/download only editor available separately	fully supported	fully supported
Sequential function chart editor 9324-RLDSFCE§	view only	upload/download only editor available separately	fully supported	editor upload/download only available separately	upload/download only editor available separately	fully supported	fully supported
Structured text editor 9324-RLDSTXE§	view only	upload/download only editor available separately	fully supported	upload/download only editor available separately	upload/download only editor available separately	fully supported	fully supported
Highly-integrated motion	view only	upload/download only	upload/download only	fully supported	fully supported	fully supported	fully supported
Graphical trending	fully supported	na	na	fully supported	fully supported	fully supported	fully supported
DriveExecutive™ Lite 9303-4DTE01ENE	available separately	available separately	available separately	included	included	included	included
PIDE autotune 9323-ATUNEENE	available separately	available separately	available separately	available separately	available separately	available separately	included
RSLogix Emulate 5000 and RSTestStand Lite 9310-WED200ENE	available separately	available separately	available separately	available separately	available separately	available separately	included
RSMACC audit support	na	na	na	na	na	na	available separately
Logix CPU security tool	included	included	included	included	included	included	included
Routine source protection tool	included	included	included	included	included	included	included
RSMACC authenticate (security server) client	included	included	included	included	included	included	included
Standalone security server explorer	included	included	included	included	included	included	included
RSLinx	Lite included	Lite included	Lite included	Lite included	Lite included	Lite included	Professional included▶
RSNetWorx for ControlNet RSNetWorx for DeviceNet RSNetWorx for EtherNet/IP¶	available separately	available separately	available separately	available separately	included▶	available separately	included▶
FBD ActiveX faceplates	included	included	included	included	included	included	included
Tag data upload/download tool	included	included	included	included	included	included	included
RSLogix 5000 project compare tool	included	included	included	included	included	included	included
Tag custom data monitor tool	included	included	included	included	included	included	included
RSview demo (50 tags/2 hours)	available separately	available separately	available separately	available separately	available separately	available separately	included
Upgrades	Service to Standard: 9324-RLD0U3xxE Service to Full: 9324-RLD0U6xxE Service to Professional: 9324-RLD0U7xxE	Mini to Standard: 9324-RLD2U3xxE Mini to Full: 9324-RLD2U6xxE Mini to Professional: 9324-RLD2U7xxE	Lite to Full: 9324-RLD25U6xxE Lite to Professional: 9324-RLD25U7xxE	Standard to Professional: 9324-RLD3U7xxE Multi-language pack extends Standard to Full♣	Multi-language pack extends Standard to Full♣	Full to Professional: 9324-RLD6U7xxE	na

*Replace "xx" in the catalog number with the appropriate language designation: EN=English, FR=French, DE=German, IT=Italian, PT=Portuguese, and ES=Spanish.

†Available as of RSLogix 5000 programming software version 12.

‡Available as of RSLogix 5000 programming software version 10.02.

§A multiple language editor package is available as 9324-RLDMLPE. It contains the function block, sequential function chart, and structured text editors at a reduced price.

¶The multiple language editor package (9324-RLDMLPE) is not the same as an upgrade, but it extends the programming languages to match those in a Full package.

♣Bundled RSNetWorx and RSLinx Professional packages use the RSLogix 5000 activation and must be installed on the same PC.

¶¶RSNetWorx for ControlNet is available as 9357-CNETL3. RSNetWorx for DeviceNet is available as 9357-DNETL3. RSNetWorx for EtherNet/IP is available as 9357-ENETL3. They are available together as 9357-ANETL3.

RSLinx Software

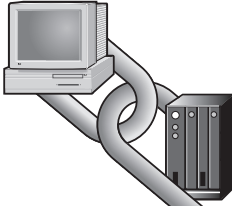

RSLinx software (9355 series) is a communication server package that provides plant-floor device connectivity for a wide variety of applications. RSLinx can support multiple software applications simultaneously communicating to a variety of devices on many different networks.

RSLinx provides a user-friendly graphical interface for navigating through your network. Select a device and click to access a variety of integrated configuration and monitoring tools. A complete set of communication drivers is provided for your networking needs, including legacy Allen-Bradley networks.

RSLinx is available in multiple packages to meet the demand for a variety of cost and functionality requirements.

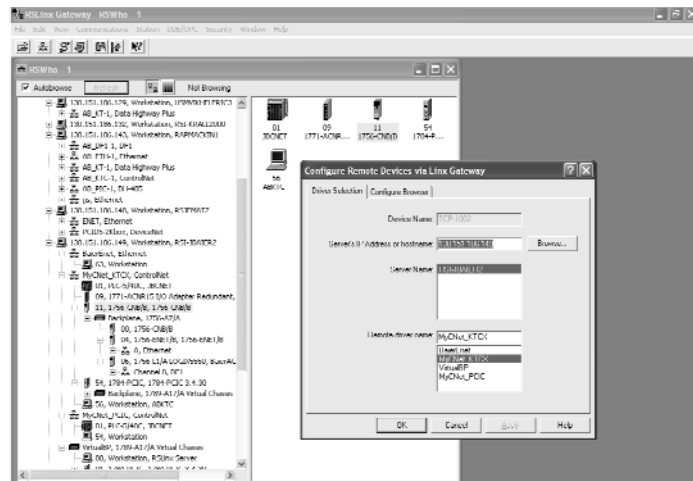

RSLinx system requirements

Description	Value
personal computer	Pentium100 MHz processor (faster processors will improve performance)
operating system	Supported operating systems: <ul style="list-style-type: none"> • Microsoft Windows XP • Microsoft Windows 2000 • Microsoft Windows NT version 4.0 with Service Pack 3 or greater • Microsoft Windows ME • Microsoft Windows 98
RAM	32 Mbytes of RAM minimum 64 Mbytes or more of RAM recommended
hard disk space	35 Mbytes of free hard disk space (or more based on application requirements)
video requirements	16-color VGA graphics display 800 x 600 or greater resolution

In most cases, RSLinx Lite software comes bundled with controller programming software packages.

Network Configuration Software

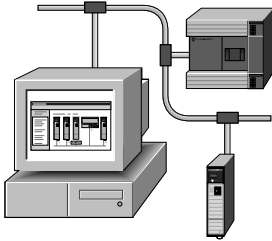

RSNetWorx software is the configuration tool for your control network. With RSNetWorx software you can create a graphical representation of your network configuration and configure the parameters that define your network.

Use RSNetWorx for:

- ControlNet to schedule network components. The software automatically calculates network bandwidth for the entire network, as well as the bandwidth used by each network component. You must have RSNetWorx software to configure and schedule ControlNet networks.
- DeviceNet to configure DeviceNet I/O devices and create a scan list. The DeviceNet scanner stores the configuration information and scan list.
- EtherNet/IP to configure EtherNet/IP devices using IP addresses or host names.

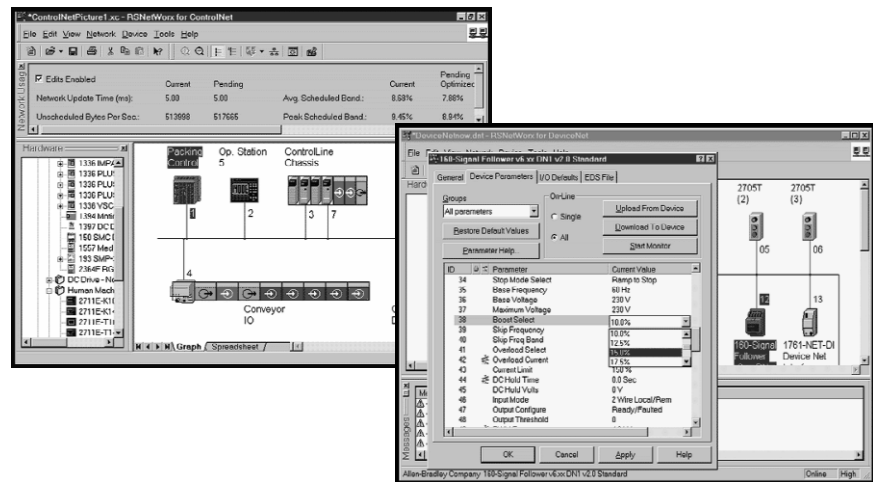

RSNetWorx system requirements

Description	ControlNet	DeviceNet	EtherNet/IP
personal computer	Intel Pentium or Pentium-compatible computer		
operating system	Supported operating systems: <ul style="list-style-type: none"> • Microsoft Windows XP • Microsoft Windows 2000 • Microsoft Windows 2000 Terminal Server • Microsoft Windows NT version 4.0 with Service Pack 6 or greater • Microsoft Windows ME • Microsoft Windows 98 		
RAM	32 Mbytes of RAM minimum more memory is required for large networks		
hard disk space	minimum: 115 Mbytes (includes program files and hardware files) full support: 168...193 Mbytes (includes program files, online help, tutorial, and hardware files)	minimum: 190 Mbytes (includes program files and hardware files) full support: 230...565 Mbytes (includes program files, online help, tutorial, and hardware files)	minimum: 108 Mbytes (includes program files and hardware files) full support: 115...125 Mbytes (includes program files, online help, tutorial, and hardware files)
video requirements	16-color VGA graphics adapter 640 x 480 resolution minimum 800 x 600 resolution recommended		
other	RSLinx Lite 2.4 or later to use RSNetWorx online	RSLinx Lite 2.4 or later to use RSNetWorx online	RSLinx Lite 2.41 or later to use RSNetWorx online

In most cases, RSNetWorx software comes bundled with controller programming software packages.

RSLogix Emulate 5000 Software



RSLogix Emulate 5000 (9310-WED200ENE) is the software emulation package for the Logix5000 controllers. RSLogix Emulate 5000 used in conjunction with RSLogix 5000 software lets you run and debug your application code while at your computer. In addition, RSLogix Emulate 5000 also lets you test HMI screens, developed in RSView for example, without the need to connect to a real controller.

You can set tracepoint and breakpoint instructions (ladder diagram only) in your application code, use traces, and also vary the execution speed of the emulator. RSLogix Emulate 5000 supports all the programming languages (ladder diagram, function block diagram, structured text, and sequential function chart). RSLogix Emulate 5000 does not allow for control of real I/O.

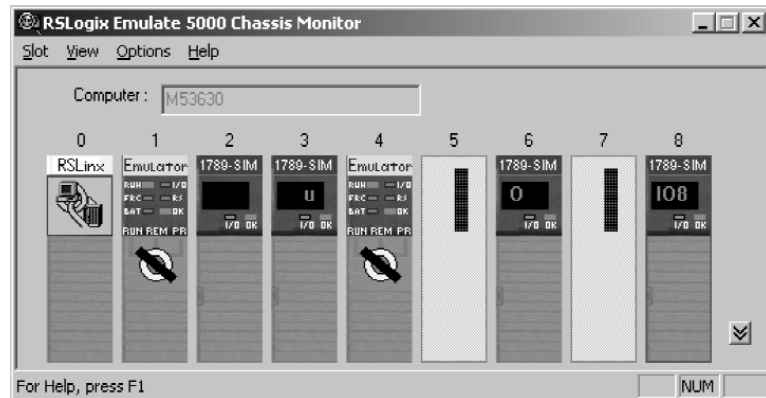

RSLogix Emulate 5000 system requirements

Description	Value
personal computer	IBM-compatible Intel Pentium II 300 MHz or Celeron 300A (Pentium III 600 MHz recommended)
operating system	Supported operating systems: <ul style="list-style-type: none"> • Microsoft Windows XP with Service Pack 1 or greater • Microsoft Windows 2000 with Service Pack 2 or greater • Microsoft Windows NT version 4.0 with Service Pack 6A or greater
RAM	128 Mbytes of RAM minimum
hard disk space	50 Mbytes of free hard disk space
video requirements	16-color VGA graphics display 800 x 600 or greater resolution

RSLogix Emulate 5000 includes RSTestStand Lite. RSTestStand Lite lets you create virtual operator consoles that can help test your application code. RSTestStand Lite can be upgraded to the standard version by ordering catalog number 9310-TSTNDENE.

RSLogix Emulate 5000 and RSTestStand Lite are included with the RSLogix 5000 Professional edition.

Logix-Based Training

Rockwell Automation offers several different levels of training for your Logix system. While most of these training aids are ControlLogix specific, the lessons and tools also apply to the other Logix platforms.

- instructor-led courses
- computer-based training
- workstation simulator
- job aids

Instructor-led courses

The instructor-led courses are best suited for people new to the Logix architecture and for those new to programmable controllers.

Course	Description
CCP142	Programming Logix5000 motion applications using ladder logic
CCP143	Developing a Logix5000 project using RSLogix 5000 software
CCP144	Configuring advanced communications options on a Logix5000 system
CCP146	Fundamentals of Logix5000 systems
CCP151	Programming Logix5000 applications using basic ladder logic
CCP152	Programming Logix5000 applications using function block diagram
CCP153	Maintaining and troubleshooting Logix5000 sequential applications

Computer-based training

The computer-based training programs are designed to provide the essential introductory information needed for using the product. Computer-based training is best used as a resource following an instructor-led course.

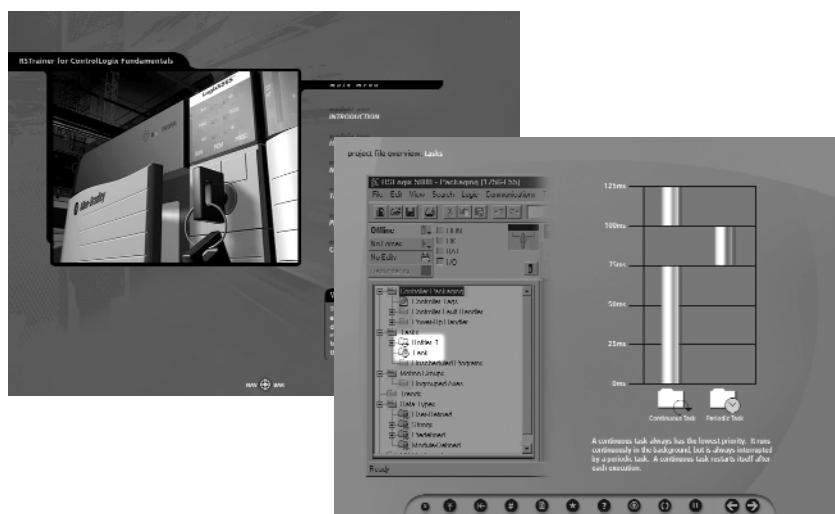

Cat. No.	Description
9393-RSTCLX	ControlLogix Fundamentals (90 day warranty)
9393-RSTPCLX	ControlLogix Fundamentals (1 year warranty)
9393-RSTLX5K	RSLogix 5000 Programming Software (90 day warranty)
9393-RSTPLX5K	RSLogix 5000 Programming Software (1 year warranty)

ControlLogix workstation simulator

The ControlLogix workstation simulator (ABT-TDCL1) is an engineering support tool that you can integrate into your training and development programs. The simulator helps you perform sequential, process, drive control, and motion control. This simulator is also used with most of the available instructor-led course. The simulator includes:

- network hardware (ControlNet, DH+)
- control hardware (controller, power supply, digital I/O modules, analog I/O modules)
- programming cable (to connect to your computer)
- motion control hardware (motion modules, servo drives, motors)
- operator interface panel (pushbuttons, potentiometers, voltmeters)

Job aids

Job aids are useful resources to take back to your facility after completing instructor-led and computer-based training.

Job Aid	Description
ABT1756TSG10	ControlLogix Glossary guide
ABT1756DRG70	ControlLogix Reference guide
ABT1756TSJ50	ControlLogix Procedure guide
ABT1756TSJ20	ControlLogix Troubleshooting guide

ViewAnyWare

ViewAnyWare products, together with Logix for control and NetLinx architecture for communication, make up Rockwell Automation's Integrated Architecture strategy. The ViewAnyWare strategy combines Rockwell Automation's expertise in Allen-Bradley electronic operator interface and industrialized PC hardware with Rockwell Software's supervisory control software. Current ViewAnyWare products include:

- RSView Enterprise Series™ software
- PanelView Plus™ operator interface
- VersaView™ industrial computers and monitors
- VersaView CE industrial computer
- MobileView™ portable HMI

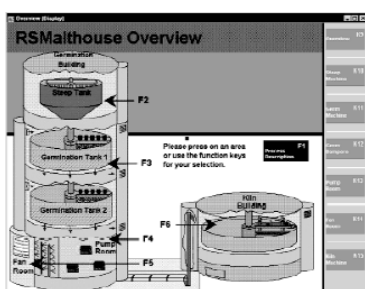

RSView Enterprise Series software

RSView Enterprise Series from Rockwell Software is a line of HMI software products designed with a common look, feel, and navigation to help speed HMI application development and training time. With RSView Enterprise Series 3.0, you can reference existing Logix data tags. Any changes made to these referenced tags are automatically inherited by RSView. RSView Enterprise Series software includes:

- RSView Studio™ lets you create applications in a single design environment. It configures Supervisory Edition, Machine Edition, VersaView CE, and PanelView Plus. It supports editing and reusing projects for improved portability between embedded machine and supervisory HMI systems.
- RSView Machine Edition™ (ME) is a machine-level HMI product that supports both open and dedicated operator interface solutions. It provides a consistent operator interface across multiple platforms (including Microsoft Windows CE, Windows 2000/XP, and PanelView Plus solutions), and is ideal for monitoring and controlling individual machines or small processes.
- RSView Supervisory Edition™ (SE) is an HMI software for supervisory-level monitoring and control applications. It has a distributed and scalable architecture that supports distributed-server/multi-user applications. This highly scalable architecture can be applied to a stand-alone, one-server/one-user application or to multiple users interfacing with multiple servers.

RSView Enterprise Series Product Line	Cat. No.	Description
RSView Studio	9701-VWSTENE	RSView Studio for RSView Enterprise Series
	9701-VWSTMENE	RSView Studio for Machine Edition
RSView Machine Edition	9701-VWMR015AENE	RSView ME Station runtime for Windows 2000, 15 displays
	9701-VWMR030AENE	RSView ME Station runtime for Windows 2000, 30 displays
	9701-VWMR075AENE	RSView ME Station runtime for Windows 2000, 75 displays
RSView Supervisory Edition	9701-VWSCWAENE	RSView SE client
	9701-VWSCRAENE	RSView SE view client
	9701-VWSS025AENE	RSView SE server 25 displays
	9701-VWSS100AENE	RSView SE server 100 displays
	9701-VWSS250AENE	RSView SE server 250 displays
	9701-VWSS000AENE	RSView SE server unlimited display
	9701-VWB025AENE	RSView SE station 25 displays
	9701-VWB100AENE	RSView SE station 100 displays
	9701-VWB250AENE	RSView SE station 250 displays
	9701-VWSB000AENE	RSView SE station unlimited display



PanelView Plus operator interface

PanelView Plus is ideal for applications with a need to monitor, control, and display information graphically, allowing operators to quickly understand the status of their application. PanelView Plus is programmed with RSVIEW Studio and has embedded RSVIEW Machine Edition functionality. It combines the best features from the popular Allen-Bradley PanelView Standard and PanelView “e” operator interface products and adds new functionality including:

- multi-vendor communications
- trending
- expressions
- data logging
- animation
- RSVIEW Studio direct browsing of RSLogix 5000 addresses



VersaView industrial computers and monitors

VersaView is a family of industrial computer and monitor solutions, comprised of integrated display computers, workstations, non-display computers and flat panel monitors. VersaView products offer effortless management of changing technology, a rugged but cost-effective design, and easier product configuration. All VersaView products provide the latest industrial solution available, optimized for visualization, control, information processing, and maintenance application. RSVIEW ME, RSVIEW SE client, and RSVIEW SE server runtimes are installed (separate activation is required).



VersaView CE industrial computers

VersaView CE is an open Windows CE terminal with a Windows desktop environment - bringing together features of operator interfaces and industrial computers. It is a high performance computer with a compact flash drive and integrated RSVIEW Machine Edition runtime (no activation required). There's no hard disk, no fan, and no moving parts, which means maximum reliability on the plant floor. Easy to set up and maintain, VersaView CE means an open system that's rugged and economical, offering high functionality in an easy to use package.



MobileView portable HMI

The MobileView family of portable HMI products lets personnel move around a machine or down a production line throughout the entire plant, resulting in greater worker and plant productivity. The MobileView interfaces let manufacturers have information and machine control wherever it is required. MobileView Machine and Guard terminals are available with RSVIEW Machine Edition running locally, eliminating the need for a server. Or, MobileView terminals act as thin clients to computer applications, such as RSVIEW Supervisory Edition, to easily integrate into new or existing control architectures.

Summary

Use a spreadsheet to record the amount and type of devices your ControlLogix system needs. For example, this sample system:

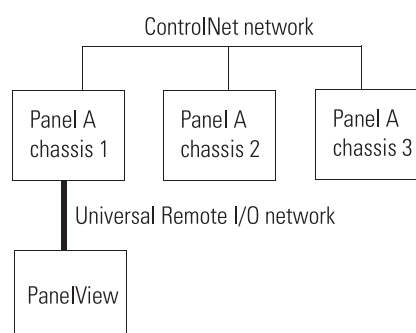

could result in this spreadsheet:

Device	Number of Points Needed	Cat. No.	I/O Points per Module	Number of Modules
120V ac digital inputs	73	1756-IA8D	8	10
120V ac digital outputs	25	1756-OA8D	8	4
24V dc digital inputs	43	1756-IB16D	16	3
24V dc digital outputs	17	1756-OB16D	16	2
contact digital outputs	11	1756-OX8I	8	2
4-20mA analog inputs	7	1756-IF6I	6	2
0-10V dc analog inputs	2	1756-IF6I	6	0 (can use remaining points on above modules)
4-20mA analog outputs	4	1756-OF6CI	6	1
analog servo module	2 axes	1756-M02AE	na	1
PanelView terminal	na	2711 series	na	na
ControlNet communication module	na	1756-CNB	na	3
Remote I/O communication module	na	1756-DHRIO	na	1
total				29

As you select devices for your ControlLogix system, keep in mind:

✓	Step	Remember to Select
	1 Select I/O devices	<ul style="list-style-type: none"> • I/O modules - some modules have diagnostic features, electronic fusing, or individually isolated inputs/outputs • a remote terminal block (RTB) or wiring system for each I/O module • PanelConnect modules and cables if connecting input modules to sensors
	2 Select motion control and drives requirements	<ul style="list-style-type: none"> • the size of the motion application (use the Motion Book) • how you want to interface the controller and drives • type of motion interface, either SERCOS or analog • associated cable(s) • remote terminal block (RTB) - only needed for the analog interface modules • drives, motors, and accessories (use the Motion Book)
	3 Select communication modules	<ul style="list-style-type: none"> • networks • communication modules • associated cable(s) and network equipment • sufficient modules and cables if you are planning a redundant system
	4 Select controllers	<ul style="list-style-type: none"> • a controller with sufficient memory • memory board for each 1756-L55 controller • 1756-BATM for larger memory size controllers • replacement batteries
	5 Select chassis	<ul style="list-style-type: none"> • a chassis with enough slots for the modules you need, with room to spare for additional growth • 1756-N2 filler strips for empty slots
	6 Select power supplies	<ul style="list-style-type: none"> • a power supply with sufficient power for the modules you need, with room to spare for additional growth • the power supply bundles if you are planning a redundant power supply system
	7 Select software	<ul style="list-style-type: none"> • the appropriate package of RSLogix 5000 Enterprise Series software and any options • other software packages for your application

As you determine placement of the modules you selected, use the worksheet on the inside of the back cover to record your choices. Make a copy of this worksheet for each chassis.

ControlLogix, Logix5550, FlexLogix, CompactLogix, DriveLogix, ProcessLogix, PowerFlex, SoftLogix5800, MicroLogix, PLC-5, PLC-3, PLC-2, SLC, DH+, Allen-Bradley, MobileView, RSLogix, RSLogix 5000 Enterprise Series, RSNetWorx, RSView Enterprise Series, RSView32, Rockwell Software, VersaView are trademarks of Rockwell Automation.

ControlNet is a trademark of ControlNet International, Ltd.

DeviceNet is a trademark of the Open DeviceNet Vendor Association.

Ethernet is a trademark of Digital Equipment Corporation, Intel, and Xerox Corporation.

Windows, Windows CE, Windows NT, Windows 2000, and Windows XP are registered trademarks of Microsoft in the U.S. and other countries.

Notes:

Notes:

www.rockwellautomation.com

Corporate Headquarters

Rockwell Automation, 777 East Wisconsin Avenue, Suite 1400, Milwaukee, WI, 53202-5302 USA, Tel: (1) 414.212.5200, Fax: (1) 414.212.5201

Headquarters for Allen-Bradley Products, Rockwell Software Products and Global Manufacturing Solutions

Americas: Rockwell Automation, 1201 South Second Street, Milwaukee, WI 53204-2496 USA, Tel: (1) 414.382.2000, Fax: (1) 414.382.4444

Europe/Middle East/Africa: Rockwell Automation SA/NV, Vorstlaan/Boulevard du Souverain 36, 1170 Brussels, Belgium, Tel: (32) 2 663 0600, Fax: (32) 2 663 0640

Asia Pacific: Rockwell Automation, 27/F Citicorp Centre, 18 Whitfield Road, Causeway Bay, Hong Kong, Tel: (852) 2887 4788, Fax: (852) 2508 1846

Headquarters for Dodge and Reliance Electric Products

Americas: Rockwell Automation, 6040 Ponders Court, Greenville, SC 29615-4617 USA, Tel: (1) 864.297.4800, Fax: (1) 864.281.2433

Europe/Middle East/Africa: Rockwell Automation, Brühlstraße 22, D-74834 Elztal-Dallau, Germany, Tel: (49) 6261 9410, Fax: (49) 6261 17741

Asia Pacific: Rockwell Automation, 55 Newton Road, #11-01/02 Revenue House, Singapore 307987, Tel: (65) 6356-9077, Fax: (65) 6356-9011